

Glossary of Sensing Terms

ac-coupled amplifier

ac-coupled amplifiers may sometimes be used reliably in close differential sensing applications, since they amplify only quick signal changes and ignore slow signal changes. As a result, very small changes in light level can be highly amplified. The output of ac-coupled amplifiers is a one-shot pulse. (See also "dc-coupled amplifier".)

In photoelectric sensing, ac-coupled amplifiers are most often used to amplify the analog signal from a non-modulated remote sensor, like model FO2BG. However, ac-coupled amplifiers may also be used with specially-designed modulated sensors such as OMNI-BEAM model OSBFAC and D12 Series ac-coupled models.

Use of ac-coupled amplifiers should be avoided, except when they are the only solution to a close differential sensing situation. Because ac-coupled amplifiers are sensitive to very small signal changes, they may respond to unwanted conditions like sensor vibration or electrical "noise".

AID™

"AID" (Alignment Indicating Device, US patent #4356393) is an exclusive Banner built-in feature that permits optimum alignment and continuous monitoring of a photoelectric sensing system. The AID system lights an indicator LED whenever the receiver "sees" its modulated light source.

In addition, a low frequency pulse rate is superimposed on the indicator LED. As alignment is improved, the pulse rate increases, indicating increased excess gain. Optimum sensor alignment is indicated by the fastest pulse rate.

The AID feature also signals when maintenance is needed. Whenever the pulse rate is slow, the lenses should be cleaned and/or the alignment checked.

alignment

Positioning of a sensor so that the maximum amount of the emitted energy reaches the receive sensing element (below).

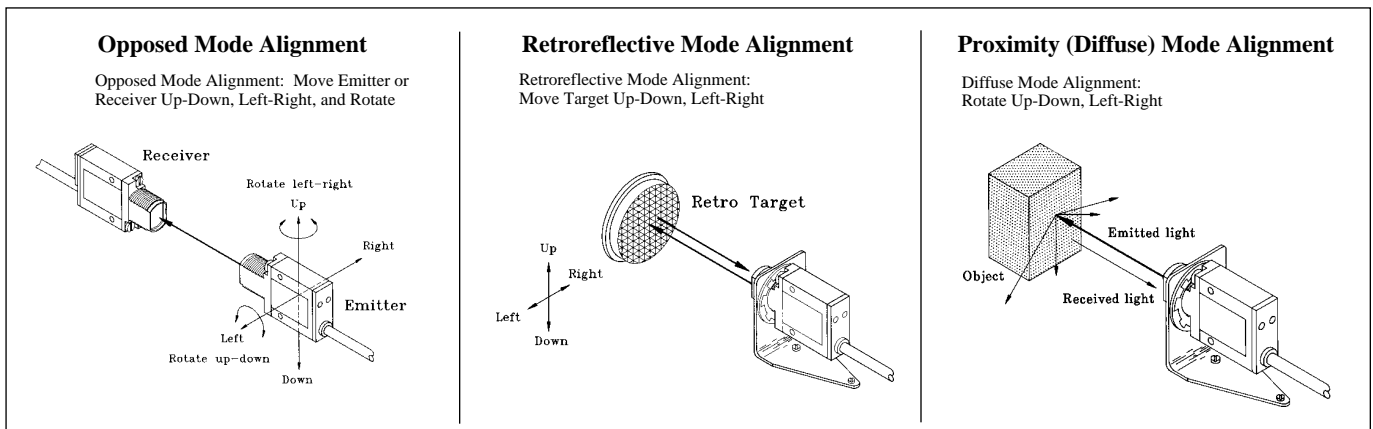

alternate action (see "flip-flop")

alternating current (ac)

A sinusoidal current rated at a given frequency, usually 50Hz or 60Hz.

ambient

The environmental conditions in a sensing area (e.g. - temperature, light level, humidity, air speed).

ambient light receiver

A non-modulated photoelectric receiver that is used to detect differences in ambient light level (using sunlight or incandescent, fluorescent, infrared, or laser light sources). Used for outdoor lighting control, sensing of hot objects (infrared), and for some indoor applications using existing factory lighting. MULTI-BEAM scanner block model SBAR1 is a good example of an ambient light receiver.

ampere (amp)

A unit of measurement of electric current. One volt across one ohm of resistance causes a current flow of one amp. One ampere is equal to 6.28×10^{18} electrons passing a point in one second.

analog output

A sensor output that varies over a range of voltage (or current) and is *proportional* to some sensing parameter (as opposed to a digital output). The output of an analog photoelectric sensor is proportional to the strength of the received light signal (e.g.-OMNI-BEAM analog sensors). The output of an analog ultrasonic proximity sensor is proportional to the distance from the sensor to the object that is returning the sound echo (e.g.-ULTRA-BEAM 923 Series sensors).

AND logic

A logic function in which all of two or more defined input conditions must exist simultaneously before a load is energized (*A and B and C = output*).

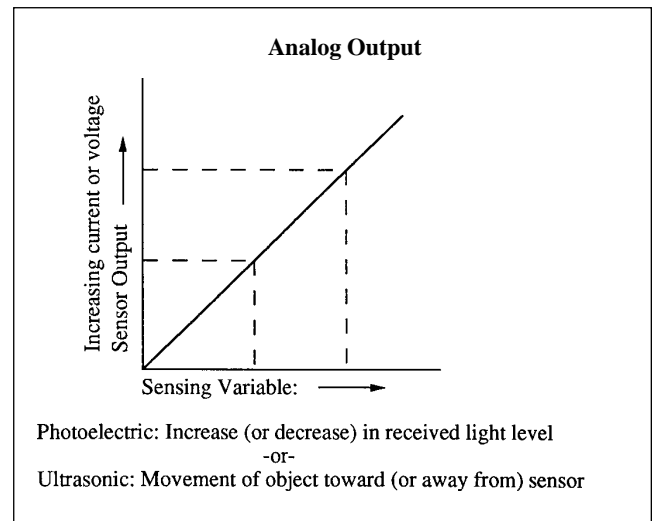

Examples of "AND" Logic

A. Using Sensor Outputs in Series

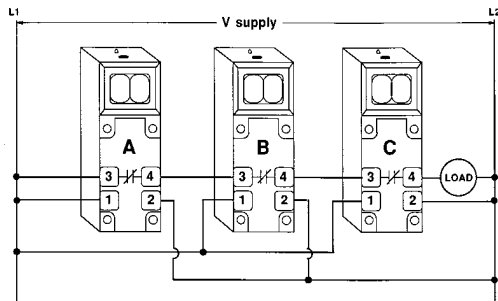

B. Using "AND" Gate Logic Module

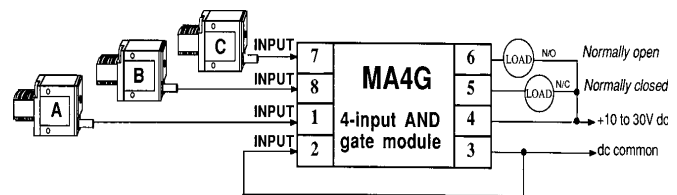

angle of acceptance

The included angle of the field of view of a sensor. See "field of view".

anode

A positive electrode of a device. See "diode".

anti-glare filter

A lens attachment consisting of a pair of polarizing filters that are oriented so that planes of polarization are at 90° to one another. Used to enable a photoelectric receiver to "see" only light of the desired polarization (from its modulated emitter), while blocking unwanted light. Used with retroreflective sensors for minimizing "proxing" effects from shiny objects.

artificial load

A resistor connected in parallel with a load to lower the load's effective resistance. Usually encountered when interfacing 2-wire sensors to high-impedance inputs in order to lower the off-state voltage at the input.

aperture

The size of a lens opening. A mechanical part attached to a lens used to restrict the size of a lens opening. Apertures are used to limit the amount of light reaching a photoelectric receiver. Apertures are used in opposed photoelectric sensing to shape the size of the effective beam to match the profile of the object to be sensed (e.g. a "line" or slit-type aperture is used on the receiver and/or emitter to sense small diameter wire or thread).

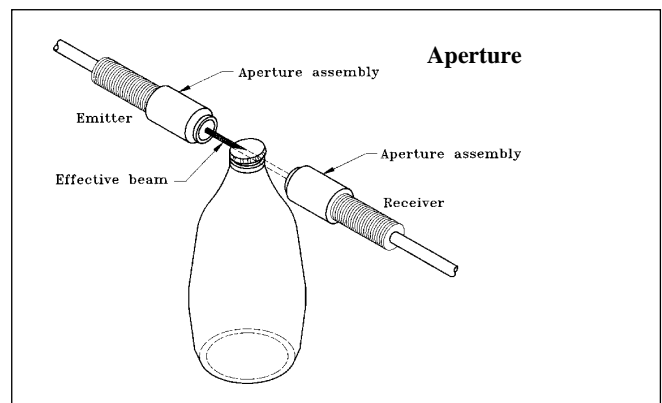

attenuation

Lessening of sensing energy caused by environmental elements such as dirt, dust, moisture, or other contaminants in the sensing area.

B Series

Banner's original product line of non-modulated solid-state amplifier and logic modules. Features aluminum construction with relay-style octal base for plug-in operation with Banner MRB or BRB control chassis. B Series modules offer complete selection of timing logic functions. Inputs are derived from non-modulated remote photoelectric sensors, contact closures, or any dc self-contained sensor or sensing system with NPN (sinking) output.

background suppression (see "fixed-field diffuse sensing mode")

barrier (see "intrinsic safety barrier")

beam-break (see "opposed sensing mode")

beam pattern

A two-dimensional graph (upper right) of a sensor's response. (Beam patterns are assumed to have the same shape in all sensing planes.) Beam patterns are plotted for perfectly clean sensing conditions, optimum angular sensor alignment, and the sensitivity (gain) setting for the specified range. Beam patterns are included as part of the description of each sensor. The dimensions of the plot are typical, and should not be considered exact specifications. Beam pattern information and assumptions are slightly different for each sensing mode. Beam patterns are helpful in predicting the the performance of the sensor.

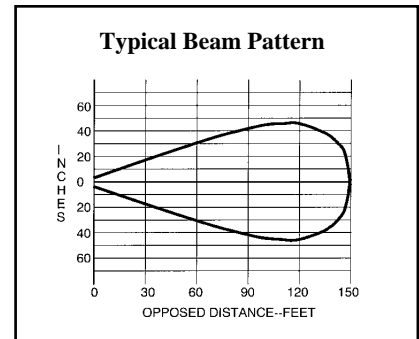

BEAM TRACKER™

A portable hand-held sensor that provides a means for troubleshooting any modulated photoelectric system. It is used to check the functioning of a modulated emitter and/or receiver, to locate the center of sensing beams during alignment, and to track down sources of severe EMI and RFI "noise". (Photo at right, above.)

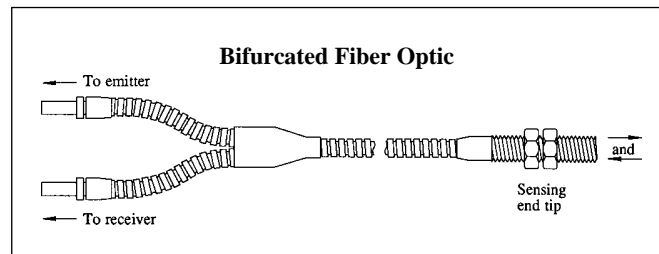

bifurcated fiber(optic)

A fiber optic assembly that is branched to combine emitted light with received light in the same assembly. Bifurcated fibers are used for diffuse (divergent) mode proximity sensing, or they may be equipped with a lens for use in the retroreflective mode.

Bi-Modal™ output

An exclusive Banner output circuit design that offers either sinking (NPN) or sourcing (PNP) output, depending upon the polarity with which the two dc supply leads are connected. Used in Banner OMNI-BEAM™ dc power blocks & SM30 sensors.

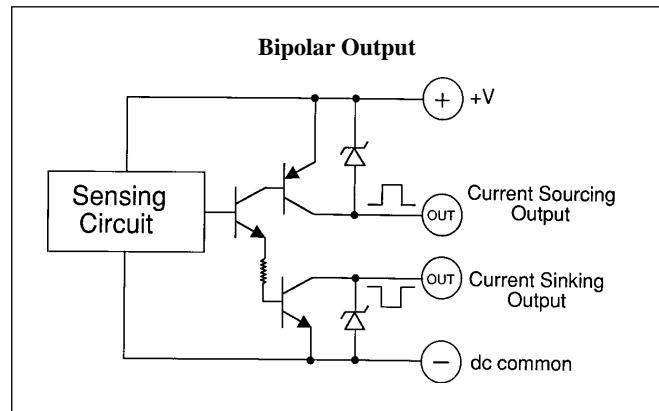

bipolar output

The dual output configuration of a dc sensing device, where one output switch is a sinking device (NPN transistor) and the other output switch is a sourcing device (PNP transistor). The solid-state equivalent of a DPST relay (for most loads).

burn-through

Describes the ability of high-powered modulated opposed mode sensors to "see" through paper, thin cardboard, opaque plastics, and materials of similar optical density. Burn-through may be used to advantage in some sensing situations, such as when looking through an opaque walled container (like a cereal box) to sense the presence or absence of product inside.

C Series (photo at right)

An alternate name for the MAXI-AMP family of stand-alone photoelectric sensor

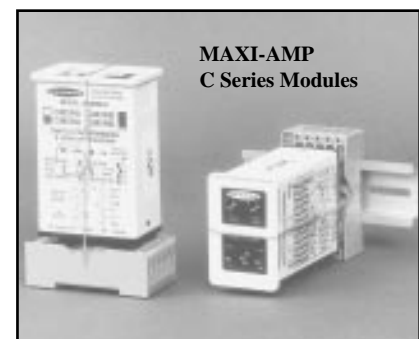

control modules and power supplies. MAXI-AMP modules combine power supply, photoelectric amplifier (some models), timing logic (some models), and output switching device into a single compact plug-in module.

capacitive sensor

Capacitive proximity sensors are triggered by a change in the surrounding dielectric. The transducer of a capacitive sensor is configured to act as the plate of a capacitor. The dielectric property of any object present in the sensing field increases the capacitance of the transducer circuit and, in turn, changes the frequency of an oscillator circuit. A detector circuit senses this change in frequency, and signals the output to change state.

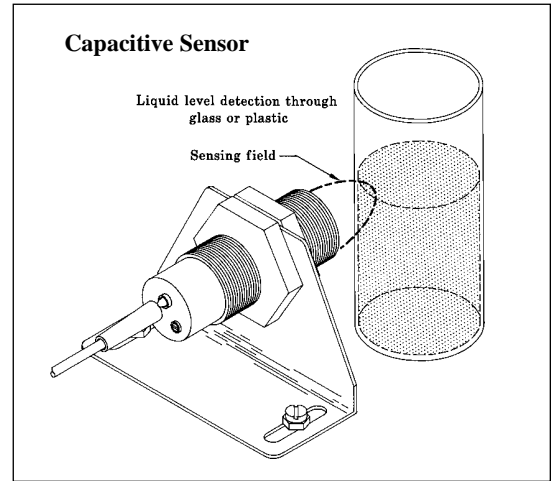

cathode

A negative electrode of a device. See "diode".

CCD array

CCD = Charge Coupled Device. A self-scanning imaging device arrayed so that the electrical charge at the output of one semiconductor element provides the input to the next. The CCD array is used as the sensing element of CCTV and inspection cameras.

CENELEC

Acronym for the European Committee for Electrotechnical Standardization. Responsible for the development of standards covering dimensional and operating characteristics of control components.

close differential sensing

Sensing situations with low optical contrast (less than 3 to 1). Includes most color registration sensing applications. Also, breaking of a large effective beam with a small profile, as in ejected part detection or thread break detection. Close differential sensing often requires the use of an ac-coupled amplifier.

CMOS

CMOS = Complementary Metal Oxide Semiconductor (device). Highly efficient semiconductors used in custom monolithic photoelectric circuit designs.

collimation

Optical collimation is the process by which a lens converts a divergent beam into a parallel beam of light.

complementary output

The dual output configuration of a sensing device, where one output is normally open and the other is normally closed. An example is a SPDT form 1C relay contact. Solid-state complementary outputs are offered in SM512, Q19, D12, and EZ-BEAM sensors and MICRO-AMP modules.

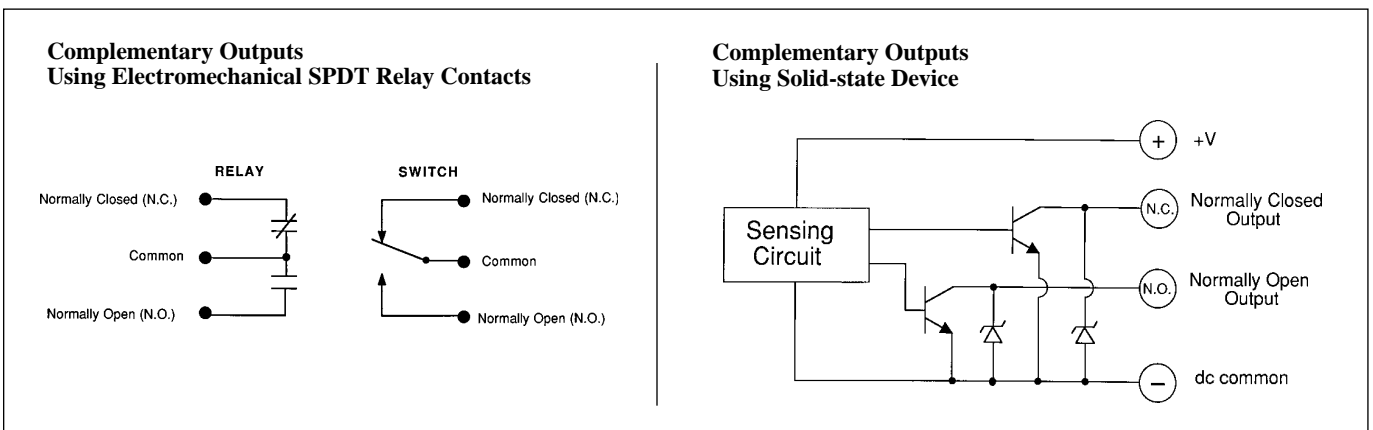

component system

A system in which sensors are remote from power supply, amplifier, logic device, and output switching device. MAXI-AMP CD, CM, or CR Series modules used with modulated remote sensors comprise component systems.

contact bounce

Occurs on the closure of a mechanical contact pair. When the contact pair closes, the contacts make and break several times before a stable closed condition is established. Contact bounce is *not* a characteristic of solid-state switch contacts.

continuous scanning

A mode of scan control in light-curtain type systems in which each scan through a beam array is followed automatically by another scan, and so on, for as long as a clock signal is present. Used in the BEAM-ARRAY Measuring Light Curtain system.

contrast (optical)

The ratio of the amount of light falling on the receiver in the "light" state as compared to the "dark" state. Contrast is also referred to as the "light-to-dark-ratio" as expressed by the equation:

$$\text{Contrast} = \frac{\text{Light level at receiver (light condition)}}{\text{Light level at receiver (dark condition)}} = \frac{\text{Excess gain (light condition)}}{\text{Excess gain (dark condition)}}$$

Optimizing the contrast in any sensing situation will increase the reliability of the sensing system.

control end

Refers to the end of a fiber optic assembly that attaches to the photoelectric sensor. An individual fiber optic assembly has one control end; a bifurcated fiber has two. See "fiber optic".

conventional current (flow)

The concept of current flow from positive to negative.

convergent beam sensing mode

A special variation of diffuse mode photoelectric proximity sensing which uses additional optics to create a small, intense, and well-defined image at a fixed distance from the front surface of the sensor lens. Convergent beam sensing is the first choice for photoelectric sensing of transparent materials that remain within the sensor's depth-of-field. Also called "fixed-focus proximity mode".

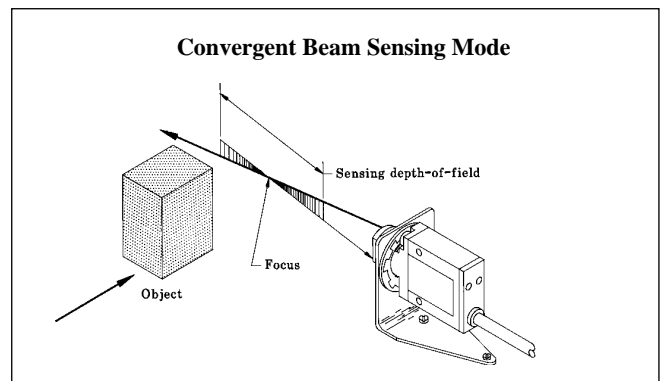

corner-cube reflector

Also called a corner-cube prism. A prism having three mutually perpendicular surfaces and a hypotenuse face. Light entering through the hypotenuse face is reflected by each of the three surfaces and emerges back through the hypotenuse face parallel to the entering beam. The light beam is returned to its source. May also be constructed from three first-surface mirrors. Corner-cube geometry is used for retroreflective materials. See "retroreflector".

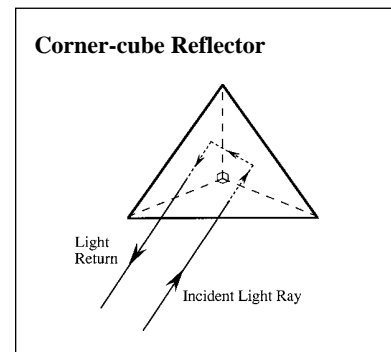

crosstalk (electrical)

Electrical crosstalk occurs in modulated photoelectric component systems when the modulated emitter signal (which is a high-current pulsed signal) couples directly onto the receiver lead wires. This results in a "lock-on" condition of the amplifier (i.e. the amplifier recognizes a light condition regardless of the sensor's status). Crosstalk is usually a result of improper splicing of additional remote sensor lead length. In component systems, remote sensors require separate shielded cables for emitter and receiver lead extension, even if the original cable length contained wires for both the emitter and the receiver.

crosstalk (optical)

Optical crosstalk occurs when a photoelectric receiver responds to light from an adjacent emitter. This is often an unwanted situation. If crosstalk cannot be resolved by repositioning of sensors, it can often be eliminated using sensor multiplexing, as with the MP-8 multiplexer module.

crosstalk (acoustical)

Acoustical crosstalk occurs when an ultrasonic sensor responds to the signal from an adjacent ultrasonic sensor. If crosstalk cannot be resolved by repositioning of the sensors, it can often be minimized by installing baffles between the sensors and/or wave guides (i.e. extension tubes) ahead of the transducers.

CSA

Abbreviation for Canadian Standards Association. A testing agency analogous to Underwriters Laboratories, Inc. (UL) in the United States. A product that is "CSA certified" has been type-tested and approved by the Canadian Standards Association as meeting electrical and safety codes. See logo at right.



current trip point amplifier

An amplifier that converts the current output signal of analog sensing devices to a trip point switch. An example is model CI3RC2 which converts the current loop output of SMI912-Series intrinsically safe sensors to a digital (switched) output.

current sinking output

The output of a dc device that switches ground (dc common) to a load. The load is connected between the output of the device and the positive side of the power supply. The switching component is usually an open collector NPN transistor, with its emitter tied to the negative side of the supply voltage.

current sourcing output

The output of a dc device that switches positive dc to a load. The load is connected between the output of the device and the ground (dc common) side of the power supply. The switching component is usually an open collector PNP transistor, with its emitter tied to the positive side of the supply voltage.

curtain of light (see "light curtain")

dark operate mode (D.O. or D/O)

The initiation of a photoelectric sensor's output (or of timing logic) when the receiver goes sufficiently dark. Most photoelectric sensors (or sensing systems) can be programmed for either dark operate or light operate.

D.A.T.A.™

Data and Trouble Alert system, an exclusive (U.S. patent 4965548) Banner sensing aid system consisting of an LED array which indicates light signal strength and sensor output state, and warns the operator of marginal sensing or failure conditions including: too high or too low gain setting, inadequate sensing contrast, too low voltage, too high internal temperature, excessive moisture inside sensor, and overloaded output. Used on Banner OMNI-BEAM™ sensors (as seen in photo at right).

dc-coupled amplifier

An amplifier in which all signal changes, slow or fast, are amplified. The amplifier's sensitivity control is actually a threshold adjustment, setting the point (in received signal intensity) at which the output will change state from "off" to "on". See also "ac-coupled amplifier".

delayed one-shot (delayed one-shot logic)

Timing logic in which an input signal initiates an adjustable delay period, at the end of which the output pulses for an adjustable pulse ("hold") time. The input signal may be either momentary or maintained. No further action occurs until the input signal is removed and then reapplied, at which time the sequence begins again. An auxiliary inhibit signal (e.g. from an inspection sensor) during the delay period will cancel the output pulse. Useful for inspection/rejection control applications. See also "on-delayed one shot".

demodulate (demodulator) (see "modulation")

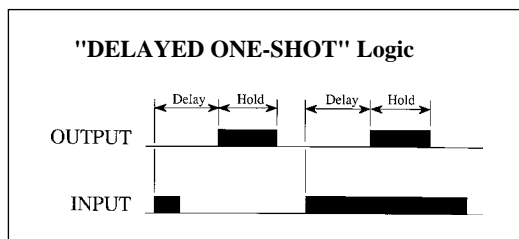
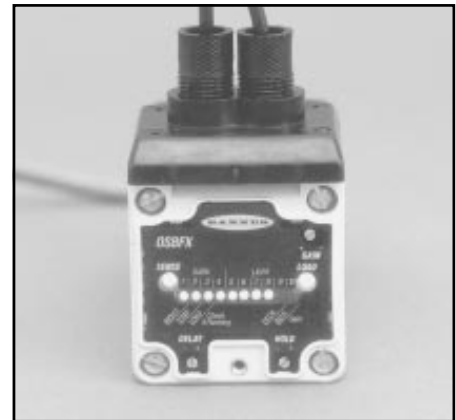
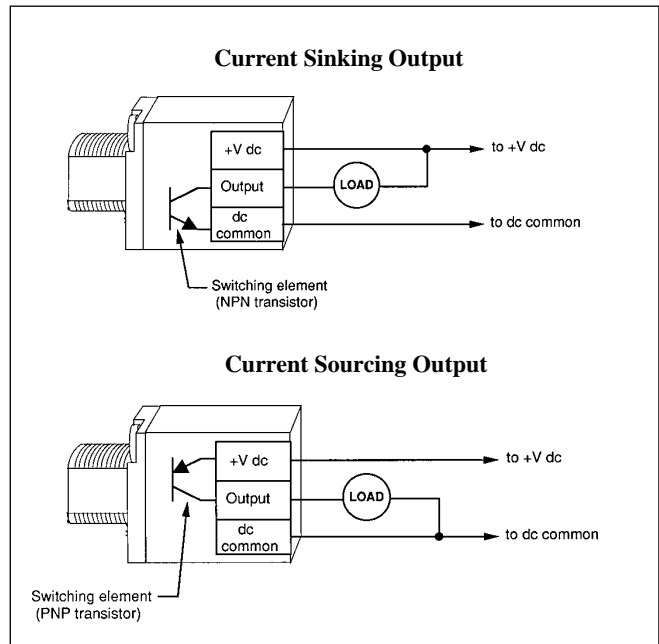

depth-of-field

The range of distance within which a sensor has response. Used to define the response pattern of proximity-mode sensors, especially ultrasonic and photoelectric convergent beam and background suppression mode sensors. See "**convergent beam sensing mode**".

diffuse sensing mode

A photoelectric proximity sensing mode in which light from the emitter strikes a surface of an object at some arbitrary angle and is diffused from the surface at all angles. The object is detected when the receiver captures some small percentage of the diffused light. Also called the "direct reflection mode" or simply the photoelectric "proximity mode".

digital output

A sensor output that exists in only one of two states: "on" or "off". The output of most sensors and sensing systems is digital.

DIN standard

Abbreviation for "Deutsches Institut für Normung". A collection of German industry standards that are recognized throughout the world.

diode

A two-layer semiconductor that allows current to flow in only one direction; from cathode to anode.

direct current (dc)

A current that flows only in one direction through a circuit. May or may not have a dc ripple component. DC sources that are unfiltered should be referred to as *full-wave* or *half-wave rectified ac*.

direct scan mode (see "opposed sensing mode")

disable

To prevent an output from occurring, despite the input signal status. See "**inhibit**".

divergent sensing mode

A variation of the diffuse photoelectric sensing mode in which the emitted beam and the receiver's field of view are both very wide. Divergent mode sensors have very forgiving alignment requirements, but have shorter sensing range as compared to diffuse mode sensors of the same basic design. Divergent sensors are particularly useful for sensing transparent or translucent materials or for sensing objects with irregular surfaces (e.g. webs with "flutter"). They are also used to reflectively sense objects with very small profiles, like small diameter thread or wire, at close range.

Examples of divergent sensors include MINI-BEAM model SM312W and remote sensor model LP400WB. All unlensed bifurcated fiber optics are divergent. The divergent mode is sometimes called the "wide beam diffuse (or proximity) mode".

diverse redundancy

A system designed under the concept of "redundancy" has components that are "backed up" to the extent that, if the failure of any single component will prevent the system from functioning properly, that component must have a counterpart which will perform the same function. "Diverse redundancy" means that the components and/or circuits are of different designs. Diversely redundant software is written with different instruction sets written by different programmers. Diverse redundancy is especially important in safety systems. Banner MINI-SCREEN, MACHINE-GUARD and PERIMETER-GUARD Systems are designed with diverse redundancy. See also *self checking*.

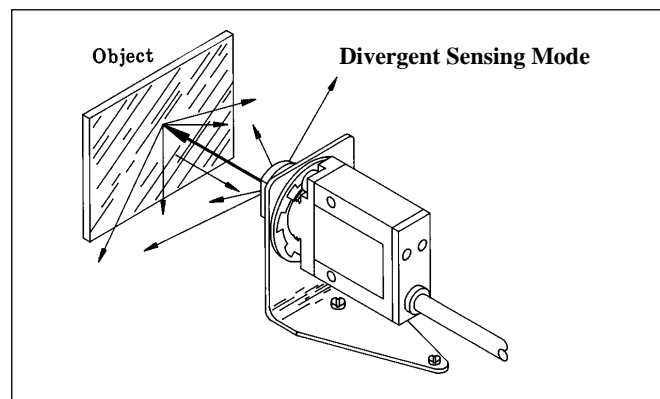
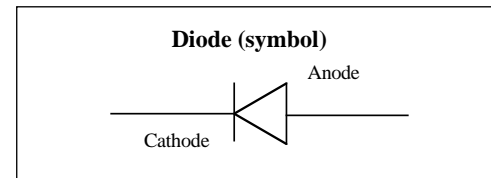
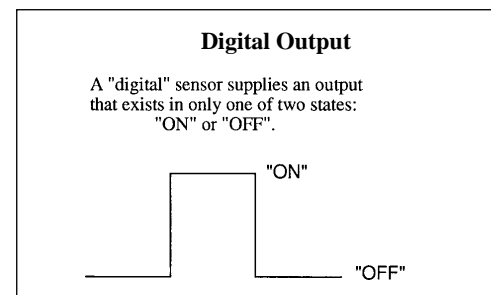
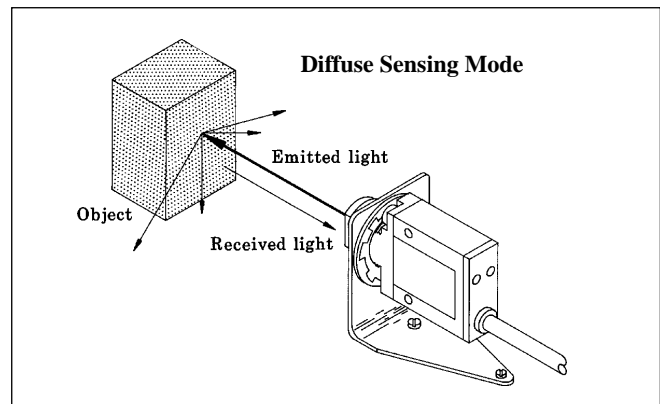

DPDT relay

Abbreviation for "Double-Pole Double-Throw". A relay with two sets of single-pole double-throw form 1C contacts that are operated simultaneously by a single action. See "**SPDT relay**".

effective beam

The "working" part of a photoelectric beam. The portion of a beam that must be completely interrupted in order for an object to be reliably sensed. Not to be confused with the actual radiation pattern of the emitter, or with the field of view of the receiver.

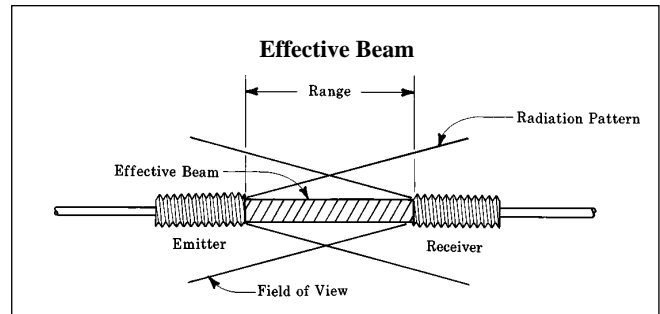

electromechanical relay

Conventional switching relays consisting of "hard" contacts (metal-to-metal), switched to opened or closed position by applying voltage to an electromagnetic coil. Can be constructed to reliably switch loads which demand much higher power levels than can be switched by most solid-state relays. Limited by relatively slow switching speeds and finite mechanical life.

electromagnetic interference (EMI)

Electrical "noise" which may interfere with proper operation of sensors, programmable logic controllers, counters, data recorders, and other sensitive electronic equipment. Common sources of EMI include lighting fixtures and controls, motors, generators, and contactors. EMI emissions are distributed evenly across the radio frequency spectrum. Emissions are readily conducted along cables, so EMI sources can often be found by following along wireways with a portable radio or with model BT-1 BEAM TRACKER.

emitter (photoelectric)

1. The sensor containing the light source in an opposed mode photoelectric sensing pair (see "**opposed sensing mode**").
2. The light emitting device within any photoelectric sensor (e.g. LED, incandescent bulb, laser diode, etc.).

enable

To allow an output to occur in response to an input signal. Synonymous with "interrogate" when used to describe the gating function in an inspection scheme. See "**inspection logic**".

excess gain

A measurement of the amount of light energy falling on the receiver of a sensing system over and above the minimum amount of light required to just operate the sensor's amplifier. In equation form:

$$\text{EXCESS GAIN} = \frac{\text{Light energy falling on receiver}}{\text{Amplifier threshold}}$$

Excess gain is a specification of every photoelectric sensor. It is plotted versus sensing distance. Excess gain values are used in the sensor selection process to predict the reliability of a photoelectric sensor in a known sensing environment.

| Excess Gain Guidelines | |
|--|----------------------|
| OPERATING ENVIRONMENT | EXCESS GAIN REQUIRED |
| Clean air; no dirt buildup on lenses or reflectors | 1.5 |
| Slightly dirty, slight buildup of lint, paper, dust, moisture, or film on lenses or reflectors; lenses cleaned regularly | 5 |
| Moderately dirty. Obvious contamination of lenses and reflector, but not obscured; Lenses cleaned occasionally or when necessary | 10 |
| Very dirty. Heavy contamination of lenses; fog, mist, or dust. Minimal cleaning of lenses. | 50 or more |

Factory Mutual Research (FM)

Tests and approves products for use in hazardous areas. See logo at right.



false pulse protection

Circuitry designed to disable the output of a sensor or sensing system until the power supply circuit has time to stabilize at the proper voltage level. Typically 100 - 300 milliseconds (this time is always specified).

FET (Field Effect Transistor)

Bilateral FETs are semiconductors used as the output switch of some sensing devices for their ability to switch either ac or dc, their low on-state voltage drop, and their low off-state leakage current. Not tolerant of inrush current, typical of inductive loads.

fiber optics

Transparent fibers of glass or plastic used for conducting and guiding light energy. Used in photoelectrics as "light pipes" to conduct sensing light into and out of a sensing area.

Glass fiber optic assemblies consist of a "bundle" of small (about .002" diameter), discrete, glass optical fibers housed within a flexible sheath. Glass fiber optics are able to withstand hostile sensing environments. Plastic fiber optic assemblies are made up of either one or two acrylic monofilaments in a flexible sheath. Plastic fiber optics are the smallest photoelectric sensors.

There are two basic styles of fiber optic assemblies: individual and bifurcated. Individual fiber optic assemblies guide light from an emitter to a sensing location, or to a receiver from a sensing location. Bifurcated fibers use half of their fiber area to transmit light and the other half to receive light. See "**individual fiber**" and "**bifurcated fiber**". (Photo, previous page.)



field of view

Refers to the area of response of a photoelectric sensor.

fixed-field diffuse mode

A photoelectric diffuse sensing mode with response that is similar to a diffuse sensor, but with a defined range limit. The amount of reflected light received by each of two optoelements is compared. An object is recognized as long as the amount of light reaching receiver R_1 is equal to or greater than the amount seen by R_2 . The sensor's output switches as soon as the amount of light at R_2 becomes greater than at R_1 .

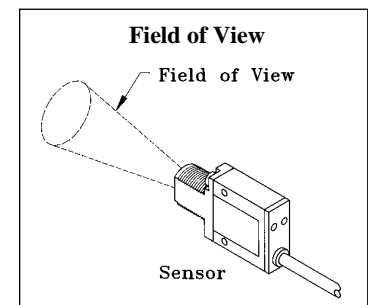

flip-flop

An electronic circuit with two stable states (Hi and Low, On and Off, etc.). The circuit remains in one of the states until application of an external signal causes it to change to the opposite state.

In sensing logic schemes, a flip-flop is a function that switches a load from "off" to "on" and back again with each sequential input. Also known as "alternate action logic", "ratchet logic", or "divide-by-two logic". Used to split production lines into two lanes.

fluorescence

The emission by a material of light radiation at a longer wavelength as a result of the absorption of some other radiation of shorter wavelengths. For example, the emission of visible light as a result of excitation by ultraviolet light.

gain adjustment (see "sensitivity adjustment")

gate

1. A combinational logic circuit having one or more input channels.
2. Used as shorthand for "interrogate". See "**inspection logic**".

glass fibers

Single glass optical fibers are small strands (typically .002 inch diameter) of glass with an outer cladding of glass of a different index of refraction (used to contain light energy as it is conducted along the fiber's length).

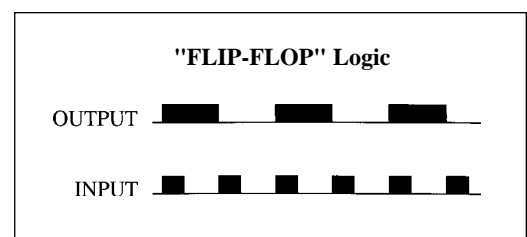
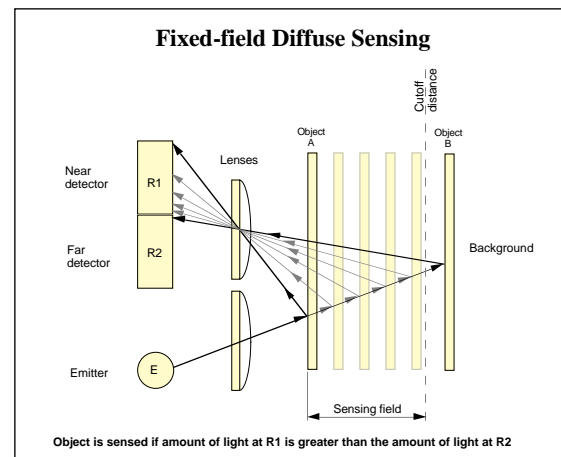

Glass fiber assemblies are constructed of a bundle of individual glass fibers, contained and protected by a sheath (typically a flexible armored cable). See "**fiber optics**".

ground

An often misused term. In power distribution systems it refers to earth ground. It is important at high power levels mainly for safety reasons.

Within a manufacturing plant, it generally refers to conduit or machine frame ground.

In electronic systems, it refers to the electronic chassis or enclosure ground or to dc common (voltage reference to the negative side of a dc power supply).

hermetic seal

An air-tight seal. In photoelectrics, the lens assemblies of some sensors have hermetic seals to exclude the entrance of air and water behind the lens, thereby preventing fogging of the inner surface of the lens.

Hertz (Hz)

The international unit of frequency, equal to one cycle per second. Named after the German physicist Heinrich Rudolph Hertz.

holding current

1) A specification of a load, especially an electromechanical load. The current that is drawn by a load while it is energized. Also called "sealed current" of a load. See "**inrush current**".

2) The current necessary to maintain a thyristor in the "on" state.

hysteresis, switching

Meaning "to lag behind". An electronic design consideration for sensors such that the operate point (received light level, etc.) is not the same as the release point of the sensor output. This differential prevents the output of a sensor or sensing system from "buzzing" or "chattering" when a signal at or near the threshold level is detected.

IEC

The International Electrotechnical Commission, headquartered in Geneva, Switzerland. This organization writes and distributes recommended safety and performance standards for electrical products and components. See "**IP rating**".

impedance

The opposition in an electric circuit to the flow of alternating current (ac) at a given frequency. Impedance consists of resistance, inductive reactance, and capacitive reactance. It is measured in ohms.

individual fiber(optic)

A fiber optic assembly having one control end and one sensing end. Used for piping photoelectric light from an emitter to the sensing location or from the sensing location back to a receiver. Usually used in pairs in the opposed sensing mode, but can also be used side-by-side in the diffuse proximity mode or angled for the specular reflection or mechanical convergent mode.

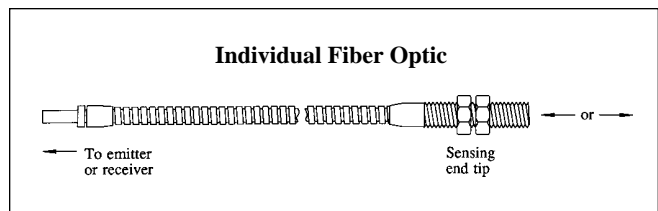

inductance

The property of an electric circuit whereby an electromotive force (emf) is induced in it by a change of current in itself or in a neighboring circuit. When a current changing at the rate of one ampere per second induces a voltage of 1 volt, the inductance of the circuit is 1 *henry*.

inductive load

Electrical devices generally made of wire that is coiled to create a magnetic field to, in turn, produce mechanical work when energized. Examples of inductive loads include motors, solenoids, and relays.

Inductive loads exhibit *inrush* of current when energized that can be many times the steady state *holding* current. When de-energized, the magnetic field collapses, generating a high voltage transient. This transient can cause arcing across mechanical switching contacts or can cause damage to solid-state contacts. See "**transient**".

inductive proximity sensor

Sensors with an oscillator and coil which radiate an electromagnetic field that induces eddy currents on the surface of

metallic objects approaching the sensor face. The eddy currents dampen the oscillator energy. This energy loss is sensed as a voltage drop, which causes a change in the sensor's output state. Often called simply a "proximity sensor".

infrared (IR)

Light with wavelengths generally greater than 800 nanometers (8000 Angstroms). Invisible to the eye and safe to most photographic films. Infrared LEDs used as the emitter source in photoelectric sensors offer the highest amount of excess gain. See "LED".

inhibit

In sensing logic schemes, an inhibit signal (e.g. from an inspection sensor) cancels a timing function and/or output. See "inspection logic".

input

1. The signal (voltage or current) applied to a circuit to cause the output of that circuit to change state.
2. The terminals, jack, or receptacle provided for reception of the input signal.

input voltage

The power source required by an electric or electronic device (e.g. a self-contained sensor) in order for the device to operate properly.

inrush current

The initial surge of current through a load when power is first applied. An important specification to consider whenever evaluating an interface. Inrush current to an inductive load (solenoid, contactor, etc.) is up to ten times the holding current.

inspection logic

A logic scheme used in high-speed inspection applications that generally uses two sensors as inputs. One sensor, called the "product sensor" senses the product's presence and "interrogates" the "inspection sensor". If the inspection sensor "sees" a good product, it "inhibits" the inspection logic from rejecting the product.

The output of the inspection logic can be a pulse to reject or a latch to divert. The output might also be used as the input to a shift register for downstream reject control. Module model LIM-2 provides programmable parameters for various inspection logic schemes.

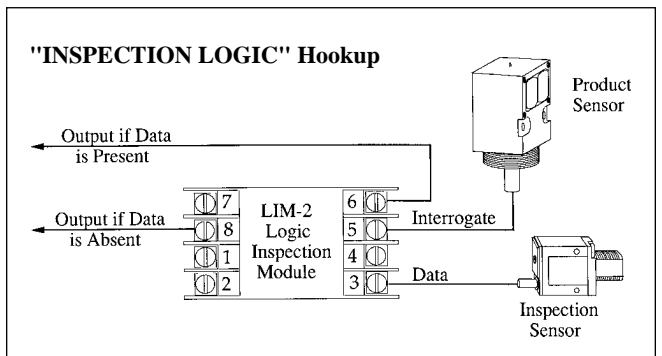
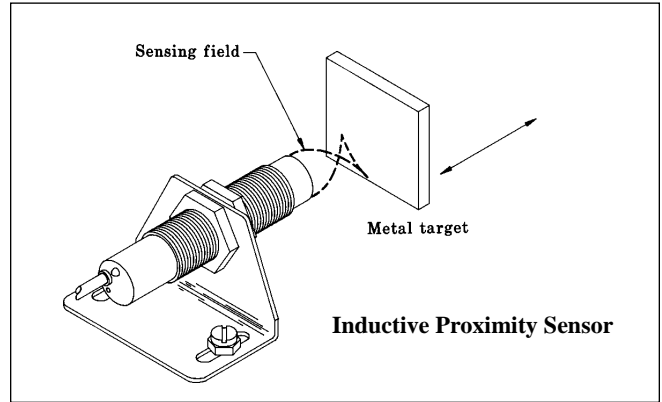

interrogate

In sensing logic schemes, an *interrogate* signal (e.g. from a product sensor) allows the information from one or more other inputs (e.g. an inspection sensor) to be recognized by the inspection or control logic. Also called "gate" or "enable". See "inspection logic".

intrinsic safety

A design technique applied to electrical equipment (e.g. sensors and switches) and wiring for hazardous locations. The technique involves limiting electrical and thermal energy to a level below that required to ignite a specific hazardous atmosphere. Intrinsic safety design often eliminates the requirement for expensive and awkward explosion-proof enclosures.

intrinsic safety barrier

A protective component designed to limit the voltage and current in a hazardous area. The barrier functions outside of the hazardous location to divert abnormal energy to ground. A barrier that is used in conjunction with an SMI Series sensor and a CI3RC2 control module makes a complete intrinsically-safe sensing system. Barriers are not required for Division 2 applications of SMI Series sensors.

inverter (circuit)

A circuit whose output is always in the opposite state (or phase) from the input. Also called a "NOT" circuit.

IP rating

A rating system established by IEC Publications 144 and 529 which defines the suitability of sensor and sensor system enclosures for various environments. Similar to NEMA ratings for enclosures. See box at right.

kilohm (k)

One thousand ohms. $1\text{k}\Omega = 1,000\Omega$

laser

An active electron device that converts input power into a narrow, intense beam of coherent visible or infrared light. The input power excites the atoms of an optical resonator to a higher energy level, and the resonator forces the excited atoms to radiate in phase. Term derived from "Light Amplification by Stimulated Emission of Radiation".

laser diode

A laser employing a forward-biased semiconductor junction as the active medium. Also called "diode laser" or "semiconductor laser".

latch (latching logic)

A logic function in which an input signal (e.g. from a sensor) locks "on" the output. The output remains "on" until a signal is applied to a second input to reset the latch.

The output of a "dc latch" will immediately latch "on" again if the input signal is present when the reset signal is removed. The reset signal of an "ac latch" will cancel the output, even if the input signal remains when the reset is removed. The output will not re-latch until the reset signal is removed and then the input signal is removed and then reapplied.

leakage current

The small amount of (undesirable) current that is inherent in solid-state switches when they are in the "off" state. Most commonly encountered with 2-wire sensors that require leakage current in order to remain powered in the "off" state. High leakage current values are also inherent in some triac switches. Becomes important if the resultant "off" state voltage across the load being switched is too high for the load to de-energize. (The "off" state voltage across the load is equal to the leakage current of the switch multiplied by the resistance of the load.)

LED (Light Emitting Diode)

A semiconductor that emits a small amount of light when current flows through it in the forward direction. In Banner photoelectric sensors, LEDs are used both as emitters for sensing beams and as visual indicators of alignment or output status (see "AID"). Banner sensors use visible red, visible green, visible yellow, or infrared (invisible) LEDs.

lens

The optical component of a photoelectric sensor that collimates or focuses emitted light rays and/or focuses incident light rays upon the receiver optoelement.

light curtain (light screen)

An array of photoelectric sensing beams configured to sense objects passing anywhere through an area (sensing plane). Some light curtains process the data from the array to measure the profile of the object or track its movement within the array. "Safety light curtains" are used to detect personnel who move into an unsafe area of a machine.

IP Ratings

1st Characteristic:

Protection against contact and penetration of solid bodies

Numeral Short Description

| | |
|---|---|
| 0 | Non-protected |
| 1 | Protected against solid objects greater than 50 mm |
| 2 | Protected against solid objects greater than 12 mm |
| 3 | Protected against solid objects greater than 2.5 mm |
| 4 | Protected against solid objects greater than 1.0 mm |
| 5 | Dust protected |
| 6 | Dust-tight |

2nd Characteristic:

Protection against the penetration of liquids

Numeral Short Description

| | |
|---|---|
| 0 | Non-protected |
| 1 | Protected against dripping water |
| 2 | Protected against dripping water when tilted up to 15 degrees |
| 3 | Protected against spraying water |
| 4 | Protected against splashing water |
| 5 | Protected against water jets |
| 6 | Protected against heavy seas |
| 7 | Protected against the effects of immersion |
| 8 | Protected against submersion |

"LATCHING" Logic

DC-Coupled Latch

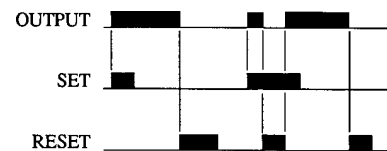

AC-Coupled Latch

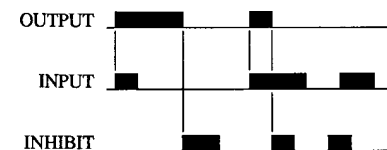

Wavelengths of Commonly-used Light Emitting Diodes (LEDs)

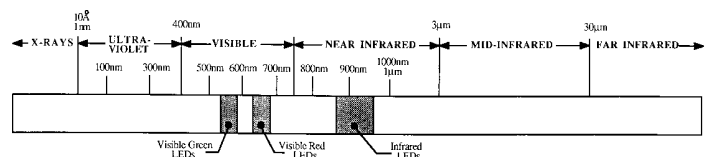

light operate mode (L.O. or L/O)

The program mode for a photoelectric sensor in which the output energizes (or the timing logic begins) when the receiver becomes sufficiently light.

limit timer

Also called a "time-limited on-off" function. A timing logic function where the output follows the input ("on-off" operation). However, an input signal that is longer than the adjustable "LIMIT" time will turn the output "off". This function is useful for conserving energy during times of machine inactivity.

linear output

Refers to the output of an analog sensor that has a "straight-line" relationship to a sensing parameter (e.g. sensing distance). A linear output is characteristic of analog ultrasonic sensors.

line-scan camera

A camera whose light-sensing element consists of a linear array of photodiodes, providing a high degree of resolution for precision measurement in one dimension. Also provides an economical means of detecting the presence or size (or feature or defect) of an object anywhere within a wide area of scan.

line voltage

The normal in-plant power line supply voltage which is usually 120 or 220/240V ac.

load

A general term for a device (or a circuit) that draws power when switched by another device (or circuit).

logic high

The higher of two voltage levels in a digital circuit.

logic level

Refers to the state of an input to or an output from a digital circuit (not applicable to analog circuits). It is always at one of only two possible voltages: "low" being a voltage usually less than 2 volts measured with respect to ground; and "high" being a voltage of some nominal level, usually within 2 volts of the positive supply.

logic low

The lower of two voltage levels in a digital circuit.

logic module

A sensing system accessory that interprets one or more input signals (e.g. from sensors, limit switches, or other logic modules) and modifies and/or combines those input signals for control of a process. A logic module is sometimes an integral part of a sensor assembly, as in OMNI-BEAM, MULTI-BEAM and MAXI-BEAM sensors with timing logic modules.

M Series

Banner's original product line of solid-state modulated photoelectric amplifier modules. Features aluminum construction with relay-style octal base for plug-in operation with Banner MRB control chassis. M Series modules offer complete selection of timing logic functions. Inputs are derived from Banner's line of modulated remote sensors. M Series modules have been superseded by the MAXI-AMP CM Series of stand alone modulated amplifier modules.

mechanical convergence

A less precise form of convergent sensing as compared to the optical convergent beam sensing mode. In mechanical convergence, an emitter and a receiver are simply angled toward a common point, ahead of the sensor(s). This approach to reflective sensing results in more efficient use of light energy as compared to diffuse mode sensing, and a greater depth-of-field than realized with true optical convergence. Sensor model SE612C is an example of mechanical convergent design. Mechanical convergence may also be customized for an application by mounting the emitter and receiver of an opposed sensing pair to mechanically converge at the desired distance. Depth-of-field is controlled by adjusting the angle between the emitter and the receiver.

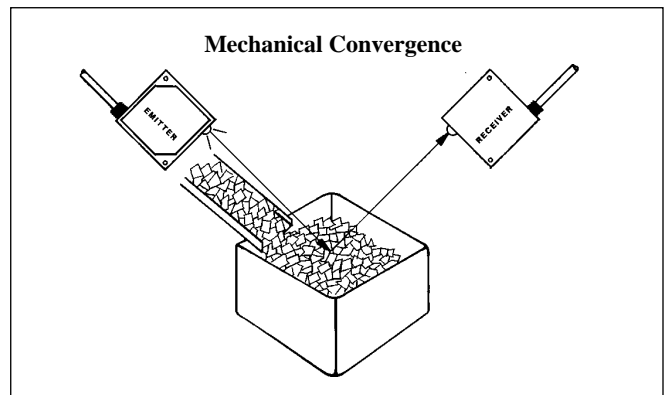
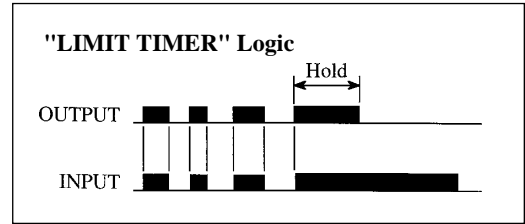

"MHS"

A model number suffix designating **Modified for High Speed**. Most often used to increase the response of modulated dc sensors with design response speed of 1 millisecond to 300 microseconds (0.3 millisecond). When this modification is made to most modulated amplifiers there is a loss of gain of about 50 percent.

microsecond

One millionth of a second. 1 microsecond = 0.000001 second or 0.001 millisecond. Abbreviated: **μs**

millisecond

One thousandth of a second. 1 millisecond = 0.001 second or 1000 microseconds. Abbreviated: **ms**

modulation

In photoelectrics, modulation of an LED simply means to turn it on and off at a high frequency (typically several kilohertz). The secret of a modulated photoelectric sensor's superior performance is that the sensor's phototransistor and amplifier are *tuned* to the frequency of modulation. Only the modulated light is amplified, and all other light which reaches the receiver is ignored. This is analogous to a radio receiver which tunes solidly to one station, while ignoring all of the other radio waves that are present in the room. In fact, a modulated sensor's LED is most often referred to as the *transmitter* or *emitter* and its phototransistor as the *receiver*.

MOV (metal oxide varistor)

A component designed to protect solid-state output devices and other sensitive electronic equipment from damaging effects of transient voltage spikes. When voltage spikes occur across an MOV, its impedance changes from very high to very low, clamping the transient voltage to a protective level. The excess energy of the high voltage pulse is absorbed by the MOV (or conducted to ground). MOVs are rated by their clamping voltage and by their peak pulse current capacity.

multiplexing

A scheme in which an electronic control circuit interrogates each sensor of an array in sequence. "True" photoelectric multiplexing enables each modulated emitter only during the time that it samples the output of the associated receiver. In this way, the chance of false response of any receiver to the wrong light source is eliminated. Model MP-8 is an example of a "true" photoelectric multiplexer.

NAMUR

Photoelectric NAMUR sensors are 2-wire devices which change their internal resistance relative to the light level reaching the receiver. They are designed for use with approved switching amplifiers, with intrinsically-safe circuits, which convert the current changes caused by the sensor's internal resistance change into a binary output signal. NAMUR sensors are most commonly used in hazardous (explosive) sensing environments.

nanometer (nm)

Unit of length used to specify the wavelength of light energy. 1 nm = 0.000000001 meter (10^{-9} meter). 1 nm = 10 Angstroms. 1 nm = .001 microns. Some typical wavelengths: red LEDs are 650 nm, green LEDs are 560 nm, infrared LEDs are 880 or 940 nm. See "LED".

NEMA

National Electrical Manufacturers Association. NEMA standards are used to specify suitability of sensor and sensing system enclosures for various sensing environments.

| | | |
|----------------|----------------|---|
| NEMA 1 | Indoor use | Protects against accidental contact by personnel & falling dirt |
| NEMA 2 | Indoor use | Protects against falling dirt & liquid & light splash |
| NEMA 3 | Outdoor use | Protects against rain, sleet, snow, dirt, & dust |
| NEMA 3S | Outdoor use | Protects against rain, sleet, snow, dirt, dust & ice buildup |
| NEMA 4 | In- or outdoor | Protects against dirt, dust, hosedown (and heavy splash) |
| NEMA 4X | In- or outdoor | Protects against dirt, dust, hosedown, & corrosion |
| NEMA 6 | In- or outdoor | Protects against dirt, dust, hosedown, & occasional submersion |
| NEMA 6P | In- or outdoor | Protects against dirt, dust, hosedown, & prolonged submersion |
| NEMA 7 | Indoor use | For use in areas of explosive gases or vapors or combustible dust |
| NEMA 9 | Indoor use | For use in areas of atmospheres containing combustible dust |
| NEMA 12 | Indoor use | Protects against dirt, dust, light splash, & oil or coolant seepage |
| NEMA 13 | Indoor use | Protects against dirt, dust, light splash, & oil or coolant spray |

noise (electrical)

Term used to collectively describe undesirable energy that may cause false response of sensing system logic or may be falsely recognized as a received signal by a sensor amplifier. Includes EMI (electromagnetic interference) and RFI (radio frequency interference).

Common sources of EMI are lighting fixtures and controls, motors, generators, and contactors. EMI is readily coupled to and conducted along wireways.

RFI generators include in-plant two-way radios, stepper motor controls, computers, and CRTs. RFI occurs most often within a narrow band of frequencies. As a result, one electronic instrument may be radically affected by presence of RF interference, while another similar instrument in the same area may appear completely immune.

Not all sources of noise are continuous. For example, an arcing relay may emit a burst of EMI *and* RFI when its contacts open. The Banner model BT-1 BEAM TRACKER is a valuable tool used in tracking the source of interfering noise.

NPN output

A transistor available as an output switch in most dc sensors and logic modules. Usually configured with its collector open and its emitter connected to ground (dc common). In this configuration, a load is connected between the output (collector) and the positive of the dc supply. This output configuration is also called a "sinking" output. See "**current sinking output**".

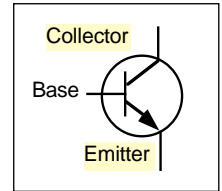

Isolated NPN transistors are sometimes offered as output switches, and can be used to either sink or source current to a circuit input. The drawing at the right shows the electronic symbol for an NPN transistor.

NPS thread

"NPS" is used as shorthand for "NPSM" which designates thread form according to the American National Standard Straight Pipe Thread for Free-fitting Mechanical Joints (ANSI B_{2.2}). This thread form is similar to the more widely recognized ANSI Standard Taper Pipe Thread (NPT), except that thread diameters remain constant along the length of the threads. NPSM threads are popular for electrical conduit assemblies where there is no requirement for sealing against internal pressure.

null

This term is used in analog sensing and control to describe the minimum voltage (or current) in an analog output range. Analog sensors have an adjustment for setting the null value.

off delay (off delay logic)

Timing logic in which the output energizes immediately when an input signal is received, and remains energized as long as the input signal is present. The off-delay timing begins at the trailing edge of the input signal, keeping the output energized. If a new input signal is received during the off-delay timing, the timer is reset, and the off-delay period begins again at the trailing edge of the new input signal. Off-delay timers allow sensing controls to ignore intermittent signal losses in tracking or flow control applications.

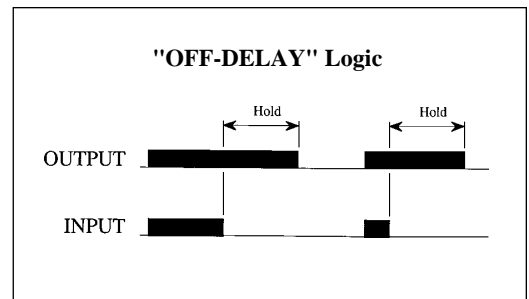

ohm

Unit of measurement for resistance and impedance. The resistance through which a current of one ampere will flow when one volt is applied.

Ohm's law

$E = I \times R$. Current (I) is directly proportional to voltage (E) and inversely proportional to total resistance (R) of a circuit.

on delay (on delay logic)

Timing logic in which timing begins at the leading edge of an input signal, but the output is energized only after the preset on-delay time has elapsed. The output ceases immediately at the trailing edge of the input signal. If the input signal is not present for the on-delay time period, no output occurs. If the input signal is removed momentarily and then reestablished, the on-delay timing starts over again from the beginning. Used to allow sensing controls to ignore short interruptions of the light beam, such as the normal flow of products past a sensor in fill-level or flow control applications.

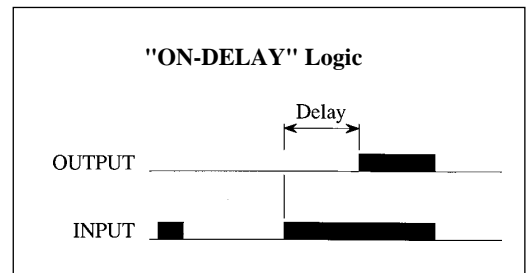

on-delayed one-shot (logic)

Timing logic which combines on delay and one-shot timing into a single function. The input signal must be present for at least the time of the on-delay in order for a timed one-shot pulse to occur. (Contrast this to "delayed one-shot" timing logic, where a timed one-shot pulse occurs for any input signal, momentary or maintained.) No subsequent output can occur until the input is removed and then reapplied, at which time the delay period begins again. Useful for jam detection applications.

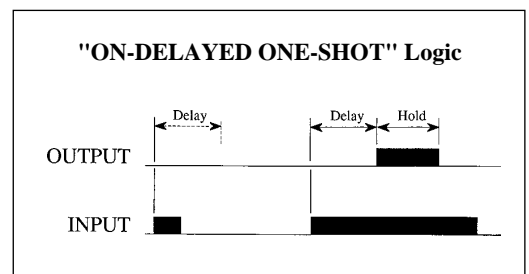

on-demand scanning (see also "continuous scanning")

A mode of scan control in light-curtain type systems in which each scan through a beam array is individually initiated when required. Used in the BEAM-ARRAY Measuring Light Curtain system.

one-shot (one-shot logic)

Timing logic in which a timed output pulse begins at the leading edge of an input signal. The pulse is always of the same duration, regardless of the length of the input signal. The output cannot reenergize until the input signal is removed and then reapplied. A one-shot timer is useful for initiating a control function keyed to the passing of either the leading or trailing edge of a product. It is also used in "on-the-fly" inspection applications (see "inspection logic"). Also called "single-shot logic", "pulse timer", or "pulse stretcher".

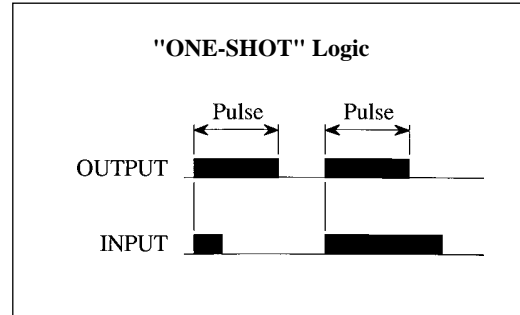

on/off delay (on/off delay logic)

Timing logic which combines on delay and off delay timing into a single function. The on delay and off delay times are often independently adjustable (in logic modules that offer timing adjustment). On/off delay logic is often used in jam and void control, high/low level control, and edgегuiding applications.

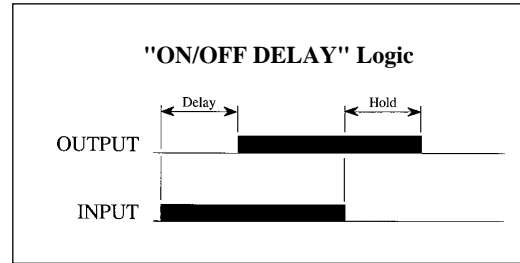

opaque

A term used to describe a material that blocks the passage of light energy. "Opacity" is the relative ability of a material to obstruct the passage of light.

open-collector

A term used to describe the NPN or PNP output of a dc device, where the collector of the output transistor is not connected to any other part of the output circuit (except through a diode for protection). Analogous to a SPST relay contact. See "NPN" and "PNP".

opposed sensing mode

A photoelectric sensing mode in which the emitter and receiver are positioned opposite each other so that the light from the emitter shines directly at the receiver. An object then breaks the light beam that is established between the two. Opposed sensing will always result in the most reliable photoelectric sensing system, as long as the item to be detected is opaque to light. Opposed sensing is the most efficient photoelectric sensing mode and offers the highest level of optical energy to overcome lens contamination, sensor misalignment, or long scanning ranges. Also often referred to as "direct scanning" and sometimes called the "beam-break" mode.

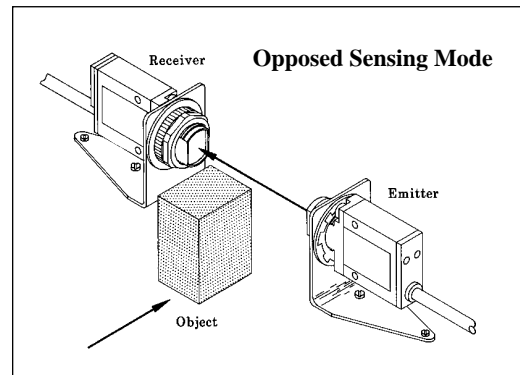

optical coupler (optical isolator)

A solid-state photoelectric device combining a light-emitting diode (LED) and a phototransistor in a single package, so that when power is applied to the LED, the phototransistor conducts. This is the equivalent of a solid-state relay contact (SPST normally open) except that normally only currents of a few milliamps can flow through the phototransistor. The advantage of this type of coupling is total electrical isolation of the output from the input. Since the input and output communicate only by light, the main use is to interface two systems without the use of interconnecting lines. The result is exceptional noise immunity. Optical couplers are of great benefit when interfacing systems which include programmable logic controllers, computers, microprocessors, and instrumentation equipment.

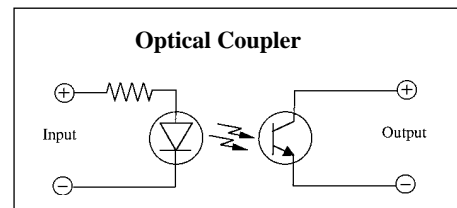

OR logic

A logic function in which the presence of any of two or more defined input conditions will cause a load to energize (A or B or C = output). Usually created by wiring all outputs in parallel to a load. See hookup, next page.

output

1. The section of a sensor or control circuit that energizes and/or de-energizes the attached load (or input).
2. The useful energy delivered by a circuit or device.

parallel operation

Refers to the interconnection of two or more output devices (e.g. several sensor outputs) in parallel to a single input or load. See "OR logic".

passive pullup (see "pullup resistor")

photocell

A resistive photosensitive device in which the resistance varies in inverse proportion to the amount of incident light. The most common light-sensitive materials used are cadmium sulfide and cadmium selenide. Such devices are characterized by resistances of from 1000 ohms to 1 megohm, response speed of several milliseconds, and color response roughly equivalent to that of the human eye. Also called "photoresistor". (See electronic symbol at right.)

photodiode

A semiconductor diode in which the reverse current varies with illumination. Characterized by linearity of its output over several magnitudes of light intensity, very fast response time, and wide range of color response. (See electronic symbol at right.)

photoelectric sensor

A device which detects a visible or invisible beam of light and responds to a change in received light intensity.

phototransistor

A photojunction device in which current flow is directly proportional to the amount of incident light. The phototransistor is characterized by impedances of from 1000 ohms to 1 megohm in most low level DC circuits. Response times are inversely proportional to incident light, but moderately high light levels yield response well under 1 millisecond. Color response is poor to greens and blues but good to reds and near infrareds. Phototransistors are well matched spectrally to infrared LEDs. (See electronic symbol on previous page)

pixel

Contraction of "picture element". An individual element in a digitized image array.

plastic fiber optics (see "fiber optics")

plug logic

A family of Banner octal-base plug-in logic modules. They operate on low voltage dc, and accept inputs from sensors and devices with NPN transistor (current sinking or isolated) or hard contact closure outputs. Popular Plug Logic modules include: model BN2-2 dual NAND gate, model LIM-2 logic inspection module, and model LSR64 shift register.

PNP output

A transistor available as an output switch in most dc sensors. Usually configured with its collector open and its emitter connected to the positive of the sensor supply voltage. In this configuration, a load is connected between the output (collector) and ground (dc common). This output configuration is also called a "sourcing" output. See "current sourcing output". The drawing at the right shows the electronic symbol for a PNP transistor.

polarized light

Light which has all component waves in the same direction of displacement. Natural light is made up of waves having a variety of displacements. Photoelectric sensors with polarizing filters emit and detect only light waves of a specific polarization, while rejecting unwanted light of other polarizations. Also, various materials "bend" light waves (alter polarization) by known amounts. This may be used to advantage to photoelectrically detect certain materials while ignoring others.

polarizing filter

A filter that polarizes light passing through it. It is possible to fabricate sheets of plastic or gelatin that contain birefringent crystals so oriented as to pass only polarized light. Also called "anti-glare filters" when used on retroreflective mode sensors.

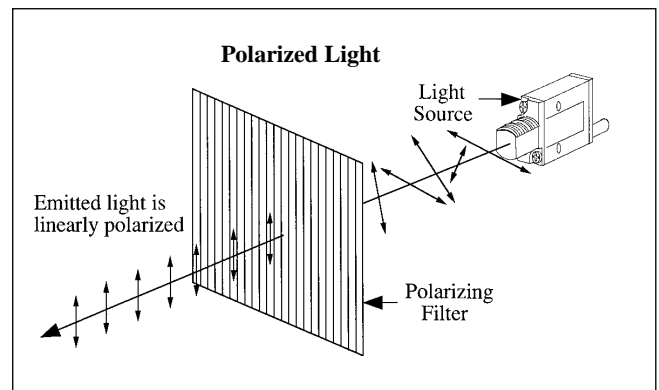
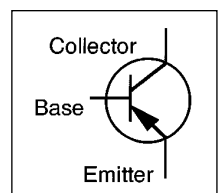
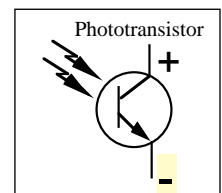
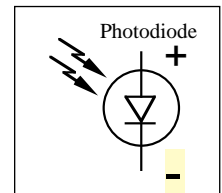
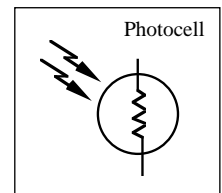
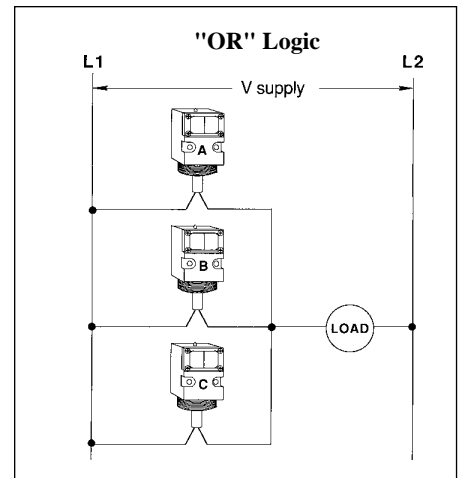

power block

The component of a modular self-contained sensor (e.g. OMNI-BEAM, MULTI-BEAM, or MAXI-BEAM) that provides the power to run the sensor and also provides the output circuitry to interface with the external load or circuit being controlled. See "**scanner block**" and "**sensor head**".

programmable logic controller (PLC)

A control device, usually used in industrial control applications, that employs the hardware architecture of a computer and relay ladder diagram language. Inputs to PLCs can originate from many sources including sensors and the outputs of other logic devices. Banner sensors and logic devices are all designed for ease of interfacing to PLCs. Also called "programmable controller".

proximity sensing mode

Direct sensing of an object by its presence in front of a sensor. For example, an object is sensed when its surface reflects a sound wave back to an ultrasonic proximity sensor. Also see "**diffuse mode (photoelectric) sensing**".

proxing

In retroreflective sensing, "proxing" is used to describe undesirable reflection of the sensing beam directly back from an object that is supposed to *break* the beam. When sufficient light is reflected from the object back to the sensor, the sensor thinks it is seeing the retroreflective target, and the object may pass undetected. This is a common problem encountered when attempting to retroreflectively sense highly reflective objects. There are a number of cures for proxing, including use of anti-glare (polarizing) filters, angling of the retroreflective sensor and its target, and substitution of opposed mode sensors.

pullup resistor

A resistor connected to the output of a device to hold that output voltage higher than the input transition level of a digital circuit. Usually a resistor connected between the output of a current sinking (NPN) device and the positive supply voltage of a logic gate.

pulse modulated (see "modulation")

pulse stretcher (see "one-shot")

PVC (polyvinyl chloride)

A member of the vinyl plastic resin family, with many applications, including jacketing of wire and fiberoptic cables. Characterized by its high degree of flexibility and good chemical resistance.

QD (quick disconnect)

A cable attachment scheme used on some Banner sensors, in which a male connector in the base of the sensor mates with the female connector of an industrial-grade cable. The QD feature is standard on ULTRA-BEAM ultrasonic sensors and on VALU-BEAM SMI912 Series intrinsically-safe sensors. A built-in QD connector is available as an option on other sensors. This feature is indicated by the letters "Q" or "QD" in the model number suffix. A QD fitting can also be installed in the wiring base of any OMNI-BEAM, MULTI-BEAM, MAXI-BEAM, or Q85 Series sensor.

radiation pattern (see "effective beam")

radio frequency interference (RFI)

Interference caused by electromagnetic radiation at radio frequencies to sensors or to other sensitive electronic circuitry. RFI may originate from radio control equipment, stepper motor controls, CRTs, computers, walkie-talkies, public service communications, commercial broadcast stations, or a variety of other sources. RFI occurs most often at a specific frequency or within a specific range of frequencies. As a result, one electronic instrument may be radically affected by the presence of RF interference, while another similar instrument in the same area may appear completely immune.

In reference to photoelectric sensing, the usual effect of RFI is the generation of false signals and the random "triggering" of equipment or processes that are controlled by the sensors. Usual curative measures include proper shielding and grounding of the affected device and also of the source, if it can be located. The Banner model BT-1 BEAM TRACKER is an invaluable aid for tracking down sources of RFI and EMI, and allows the tracking of RFI across open areas.

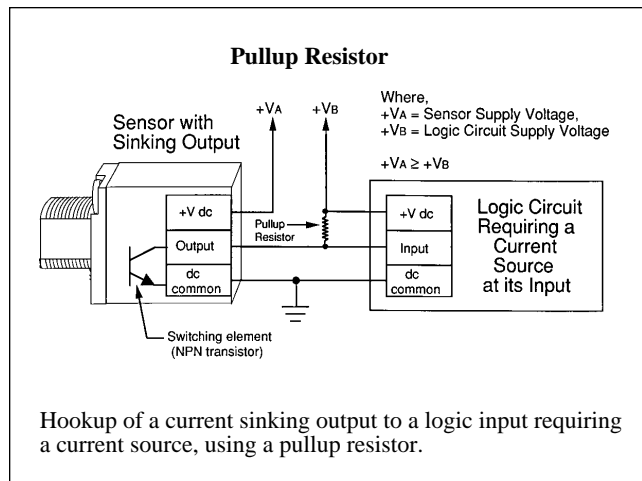

range (sensing range)

The specified maximum operating distance of a sensor or sensing system:

Opposed sensing mode: the distance from the emitter to the receiver

Retroreflective sensing mode: the distance from the sensor to the retro target

Proximity sensing modes: the distance from the sensor to the object being sensed

ranging (see "sensing window")

rate sensor

Timing logic in which overspeed or underspeed conditions are sensed by a circuit that continuously monitors and calculates the time between input signals, and compares that time with a preset reference. In Banner rate sensing logic the output *drops out* if the preset rate is not met (underspeed) or is exceeded (overspeed).

receiver

The transducer element that responds to the sensing energy. Also the name for the half of an opposed pair of photoelectric or ultrasonic sensors that receives the sensing energy from the emitter.

reflectivity (relative)

A measure of the efficiency of any material surface as a reflector of light, as compared to a Kodak white test card which is arbitrarily rated at 90% reflectivity. Relative reflectivity is of great importance in photoelectric proximity modes (diffuse, divergent, and convergent), where the more reflective an object is, the easier it is to sense. See table, next page.

reflex sensing mode (see "retroreflective sensing mode")

refraction

The "bending" of light rays as they pass through the boundary from a medium having one refractive index into a medium with a different refractive index. For example, as from air into water or from air into glass or plastic.

registration mark

A mark printed on a material using a color that provides optical contrast to the material color. The mark is sensed as it moves passed a photoelectric color sensor. Registration marks are used for cutoff control as in a wrapping or bagging operation, or for product positioning as in a tube end crimping process.

relay

A switching device, operated by variations in the conditions of one circuit, which serves to make or break one or more connections in the same or another circuit. May be mechanical, as in the common electromechanical relay having an electromagnetic coil and metal contacts. Or, may be solid-state, in which switching is accomplished by a solid-state element such as a transistor or SCR. Relays are used as output switching devices for sensors and control modules, and serve to interface the sensor or module to the circuit under control.

remote sensor

The remote photoelectric sensor of a *component system* contains only the optical elements. The circuitry for system power, amplification, logic, and output switching are all located at a central location, typically in a control cabinet. As a result, remote sensors are generally the smallest and the most tolerant of hostile sensing environments. Remote sensors include those which are used with the Banner MAXI-AMP & MICRO-AMP modules.

rep rate (scan rate)

In photoelectrics, this term is used to describe the time taken to interrogate each optoelement in a scanned array of receivers (e.g. for a line-scan camera, a multiplexed array of emitters and receivers, or a light curtain). It is the time from the start of one complete scan until the start of the next scan. The rep rate is one parameter that determines the system response speed. In general, higher light level is required for faster rep rates.

RELATIVE REFLECTIVITY TABLE

| Material | Reflectivity (%) | Excess Gain Required |
|-------------------------------|-------------------------|-----------------------------|
| Kodak white test card | 90% | 1 |
| White paper | 80% | 1.1 |
| Masking tape | 75% | 1.2 |
| Beer foam | 70% | 1.3 |
| Clear Plastic* | 40% | 2.3 |
| Rough wood pallet (clean) | 20% | 4.5 |
| Black neoprene | 4% | 22.5 |
| Natural aluminum, unfinished* | 140% | 0.6 |
| Stainless steel, microfinish | 400% | 0.2 |
| Black anodized aluminum* | 50% | 1.8 |

*NOTE: For materials with shiny or glossy surfaces, the reflectivity figure represents the maximum light return, with the sensor beam *exactly perpendicular* to the material surface

repeat-cycle timer (repeat cyclcr)

Timing logic in which an input signal begins a delay period, during which there is no output. If the signal remains, the delay period is followed by a hold period, during which the output is energized. If the input signal remains after the first hold period, a new delay period is started, followed by the hold period, etc. This sequence continues indefinitely until the input signal is removed. Delay and hold times are independently adjustable (where times are not fixed). One application is in edgeguide and other guidance control applications where it is desirable to pulse the correction mechanism to avoid overcorrection that might occur with a continuous output.

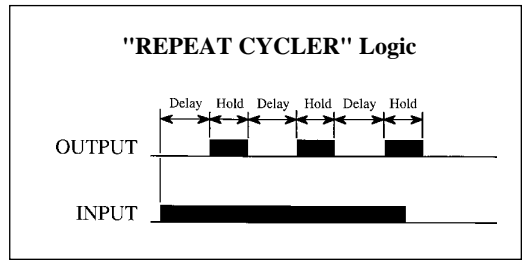

repeatability

A measure of the repeat accuracy of a sensor and/or timer and/or control mechanism (e.g. motor, brake, solenoid, etc.). Usually expressed as a distance or time.

resistance

The opposition to the flow of electric current. That property of a material which impedes electrical current and results in the dissipation of power in the form of heat. Measured in ohms.

Resistor (symbol)



resolution

In presence sensing: the smallest part profile dimension that will be reliably sensed.

In position sensing applications: the smallest increment of distance that can be repeatably sensed.

In line-scanning: the projected distance between two adjacent pixels, i.e. the size of the field-of-view divided by the number of pixels in the CCD array.

response time (response speed)

The time required for the output of a sensor or sensing system to respond to a change of the input signal (e.g. a sensing event). Response time of a sensor becomes extremely important when detecting small objects moving at high speed. Narrow gaps between adjacent objects also must be considered when verifying that sensor response is fast enough for an application.

$$\text{Required Sensor Response Time} = \frac{\text{Apparent object (gap) size as it passes the sensor}}{\text{Velocity of the object as it passes the sensor}}$$

retriggerable (one shot)

One of two types of one-shot timing logic. The output pulse of a *retriggerable* one-shot is restarted with the reoccurrence of every input. The output will remain "on" as long as the time between consecutive inputs is shorter than the one-shot pulse time.

A *non-retriggerable* one-shot timer must complete its output pulse before it will recognize any new input signals. Sometimes they offer an advantage in indexing or registration control applications where multiple input signals are possible during the advance of the product.

retroreflective sensing mode

Also called the "reflex" mode, or simply the "retro" mode. A retroreflective photoelectric sensor contains both the emitter and receiver. A light beam is established between the sensor and a special retroreflective target. As in opposed sensing, an object is sensed when it interrupts this beam.

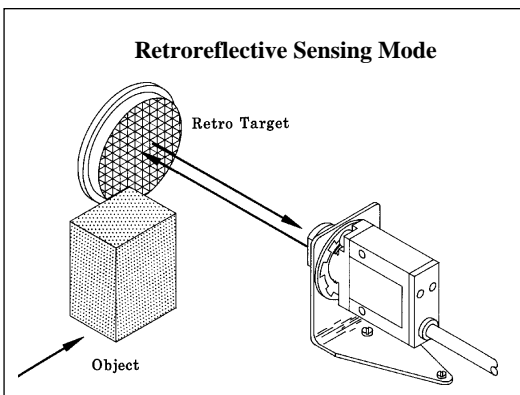

"RETRIGGERABLE ONE-SHOT" Logic

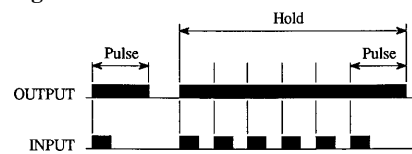

"NON-RETRIGGERABLE ONE-SHOT" Logic

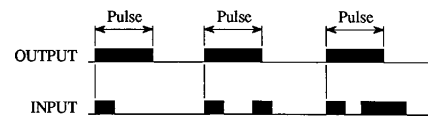

Retro is the most popular mode for conveyor applications where the objects are large (boxes, cartons, etc.), where the sensing environment is relatively clean, and where scanning ranges are typically a few feet. Retro is also used for code reading applications. Automatic storage and retrieval systems and automatic conveyor routing systems use retroreflective code plates to identify locations and/or products.

retroreflector

A reflector used in retroreflective sensing to return the emitted light directly back to the sensor. The most efficient type have corner-cube geometry (see "**corner-cube reflector**"). Reflective tapes use glass beads or smaller, less efficient corner-cubes. (Photo at right.)

reverse polarity protection

Refers to the design feature of Banner dc sensors which protects them from damage due to accidental reverse wiring to the power supply. Sensors without reverse polarity protection may be destroyed by accidental wrong-polarity connections.

ripple

An ac voltage component on the output of a dc power supply. Usually expressed as a percentage of the supply voltage. Ripple may be suppressed ("smoothed") with capacitor filtering. Most dc-only devices require less than about 10% ripple for reliable operation.

saturation voltage

The voltage drop appearing across a switching transistor or SCR that is fully turned "on". See "**voltage drop**".

scanner block

The modular component of Banner MULTI-BEAM sensors that contains the optoelements plus all of the emitter and/or receiver circuitry. The scanner block housing accommodates the other two modules: the power block and the logic module. The scanner block is supplied with a lensed upper cover and a lower cover that provides access to the wiring chamber. (Photo at right.)

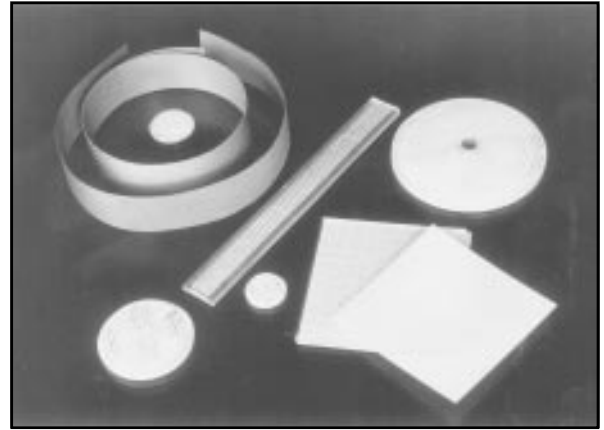

Exploded view, MULTI-BEAM Sensor

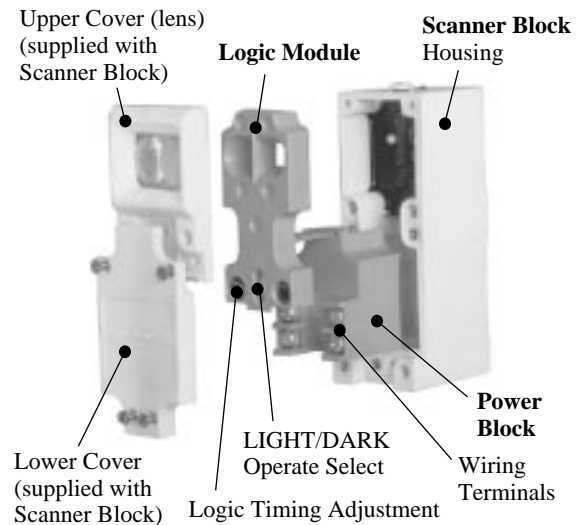

Exploded view, MAXI-BEAM Sensor

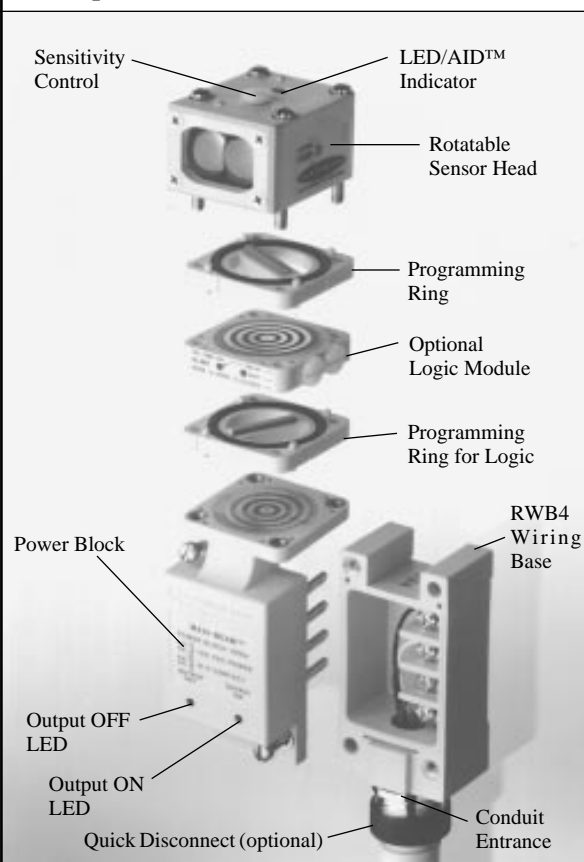

sensor head (sensor block)

The modular component of Banner OMNI-BEAM and MAXI-BEAM sensors that contains the optoelements, emitter and/or receiver circuitry, and lenses. The sensor head attaches to the power block with four bolts, and interconnects to the rest of the sensor circuitry with a wireless connector. In MAXI-BEAMS, the sensor head is rotatable around the vertical center axis in four 90° increments. (See photo, left.)

SCR (silicon controlled rectifier)

Also known as a "reverse blocking triode thyristor". A semiconductor device used as the output relay in many ac sensors and modules. It normally acts as an open circuit, but switches rapidly to a conducting state when an appropriate gate signal is applied.

self-checking (circuitry)

A circuit having the capability to electronically verify that all of its own critical components, along with their redundant backups, are operating properly. Banner MINI-SCREEN, MACHINE-GUARD, and PERIMETER-GUARD Systems are self-checking.

self-contained sensor

A sensor that contains the sensing element, amplifier, power supply, and output switch in a single package. Examples include Banner MULTI-BEAM, MAXI-BEAM, OMNI-BEAM, VALU-BEAM, MINI-BEAM, ECONO-BEAM, and ULTRA-BEAM sensor families. (See photo, below.)

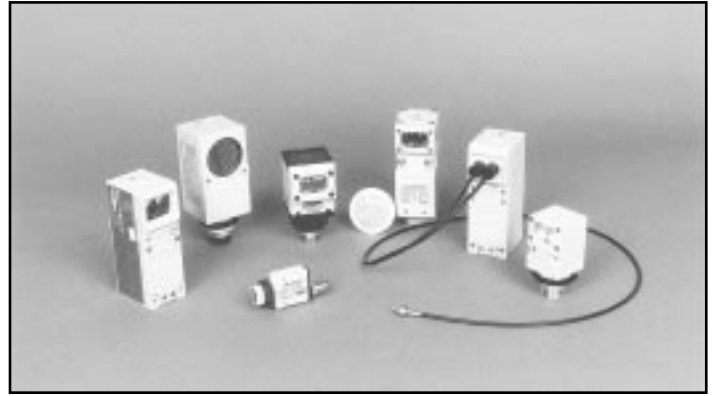

sensitivity adjustment

An adjustment made to a sensor's amplifier that determines the sensor's ability to discriminate between different levels of received sensing energy (e.g. between two light levels reaching a photoelectric receiver). The adjustment control is usually a potentiometer located either on the sensor (if self-contained) or on a remote amplifier. Sometimes called the "gain adjustment".

sensing end

Term used to describe the end of any fiber optic cable at which sensing takes place (i.e. the end at which objects to be sensed are located). Sensing ends are manufactured in many mounting styles, and the sensing ends of glass fiber optic assemblies may be shaped to match the profile of the object to be sensed. See "**bifurcated fiber**" or "**individual fiber**".

sensing window

Glass fiber optics: the size and shape of the fiber optic bundle as it is terminated on the sensing end. Sensing windows may be round, rectangular or other shapes. A single bundle of glass fiber optics may terminate in several sensing windows.

Analog sensing: the range of distance over which the sensor will recognize an object and produce an output. The near and far limits of the sensing window are set by the null and span controls, respectively. Sensing within a window is also called "ranging".

series operation

Refers to the interconnection of two or more output devices (e.g. several sensor outputs) in series to a single load. See "**AND logic**".

shift register

A logic scheme that indexes ("clocks") data along a specified route (through "registers") and outputs that data at a programmed point. Shift registers are used as logic in sensing systems to coordinate the inspection of a product at one location and to allow the resultant action (if any) to take place at a location downstream in the process. The clock signal is usually generated by a second input that is tied to the mechanical movement of the transport mechanism (e.g. a signal generated by a cam or a sprocket on a conveyor drive, index wheel, etc.).

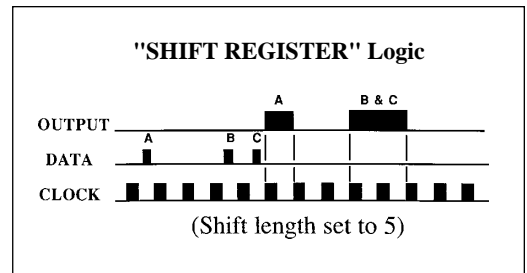

short circuit protection

The ability of a solid-state output device or circuit to endure operation in a shorted condition indefinitely or for a defined period of time with no damage.

showering arc (test)

NEMA test standard ICS 1-109. A severe test for the immunity of an electronic circuit (e.g. a self-contained sensor) to EMI. Consists of a calibrated arc drawn across a pair of open contacts. The test stand has a 100 foot multi-conductor cable that has two of its wires connected to the arcing contacts. The power and/or output circuits of the device under test are connected to other wires within the same 100 foot cable to simulate the noise coupling that occurs within wireways of machine systems.

single-shot (see "one-shot")

sinking output (see "current sinking output")

skew angle

An alignment technique used in diffuse, retroreflective and convergent mode sensing to increase the optical contrast ratio. In diffuse and convergent sensing, it is done to reduce *background* reflections. The sensor is angled so that its beam strikes the background at an angle *other* than 90 degrees (i.e. straight on).

In retroreflective sensing, skewing the sensor is done to reduce the amount of light reflected directly back from the *object* that is supposed to break the beam established between the sensor and its retro target.

SMD (surface mount device)

Surface mount devices are flat, rectangular, leadless discrete electronic components that are much smaller than equivalent components with lead wires. Their small size significantly reduces the overall size of circuitry and electronic assemblies. Their leadless design and consistent geometry allows robotic placement of the components onto a PC board. They attach to one side of pre-solder masked PC boards by heating the entire board assembly and reflowing the solder. Most state-of-the-art sensors make use of SMD technology.

snubber

A series combination of a resistor and a capacitor (R-C network) used to limit the maximum rate of rise of a voltage. Snubbers are connected across the contacts of electromechanical relays that switch a large resistive load or any inductive load, to suppress contact arcing. Snubbers are used across solid-state relay contacts to help prevent false turn-on of the switch by voltage transients. Also called a "snubber network".

solid-state relay (see "relay")

sourcing output (see "current sourcing output")

span

This term is used in analog sensing and control to describe the maximum voltage (or current) in an analog output range. Analog sensors have an adjustment for setting the span value.

specular sensing mode (specular reflection)

A photoelectric sensing mode where an emitter and a receiver are mounted at equal and opposite angles from the perpendicular to a highly reflective (mirror-like) surface. The distance from the shiny surface to the sensors must remain constant. The specular sensing mode is useful in some applications where it is necessary to differentiate between a shiny and a dull surface. It is particularly useful for detecting the presence of materials which do not offer enough height differential from their background to be recognized by a convergent or fixed-field mode sensor. A common example is sensing cloth (diffuse) on a steel sewing machine table (shiny).

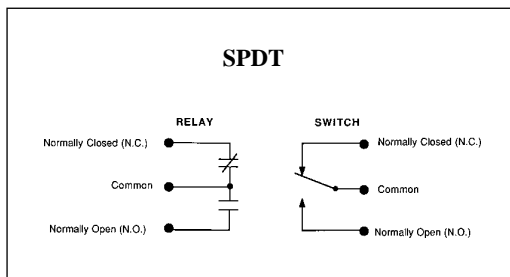
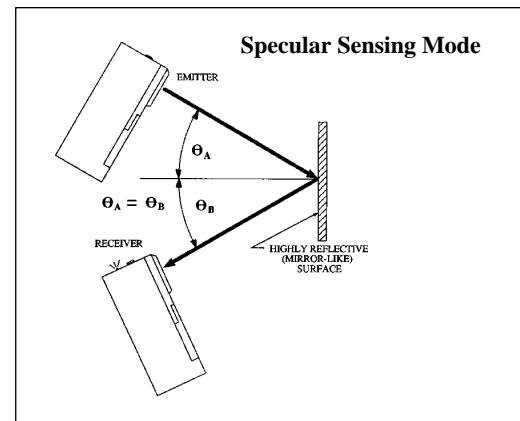
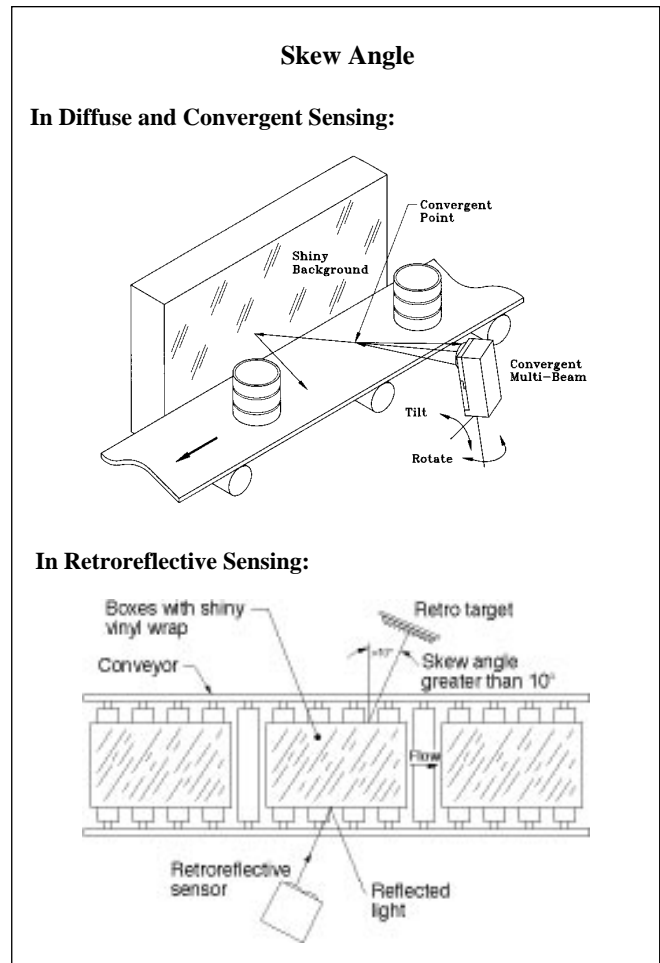

SPDT

Abbreviation for "Single Pole Double Throw". Refers to a switch or an electromechanical relay having one set of form 1C contacts. One contact is open when the other is closed (complementary switching).

SPST

Abbreviation for "Single Pole Single Throw". Refers to a switch or a relay contact (electromechanical or solid-state) with a single contact that is either normally open or normally closed.

threshold (of a photoelectric amplifier)

The value of voltage in a dc-coupled photoelectric amplifier that causes the output of the sensor or sensing system to change state. This voltage level is directly related to the amount of light that is incident on the photoelectric receiver. The threshold is the value of received signal representing an excess gain of **1x**. The sensitivity control (where one is available) adjusts the threshold voltage level.

through-beam sensing mode (see "opposed sensing mode")

tracer beam

A visible red beam available with many Banner modulated infrared emitters, used as an alignment aid. The tracer beam is inactive, in that it does not supply any of the sensing energy. The sensing energy is supplied by an invisible infrared beam.

The tracer beam is used during alignment to mechanically align the emitter to the receiver. A retroreflective target is temporarily attached to the lens of the receiver, and the tracer beam is sighted on the target from behind the emitter. The retro target is then removed and fine alignment is made using the AID signal strength indicator. The tracer beam is also used as a "power-on" indicator for the emitter. Tracer beams are a feature of MAXI-BEAM and VALU-BEAM infrared emitters.

transducer

A device that converts energy of one form into another form. The sensing element of a non-contact presence sensor that converts a change in incident sensing energy (e.g. light, sound, etc.) into a proportional electrical quantity such as voltage or current.

transient

A very short duration pulse of voltage (or current) that is many times larger in magnitude than the supply voltage. Transients are usually caused by the operation of a heavy load or of any size inductive load like motors, contactors, and solenoids.

Voltage transients can cause false actuation of fast electronic circuits such as solid-state counters, one-shot timers, and latching outputs. The problems resulting from transients are dealt with by careful shielding and grounding of remote sensor lead wires, by physical separation of signal wires from power wires in wireways, and by installing transient suppressors directly across offending loads.

translucent

Term used to describe materials that have the property of reflecting a part and transmitting a part of incident radiation.

2-wire sensor

A sensor designed to wire in series with its load, exactly like a limit switch. A 2-wire sensor remains powered when the load is "off" by a residual "leakage current" that flows through the load.

UL

Abbreviation for "Underwriters Laboratory, Inc.", a testing agency for products sold in the United States. A device that has "UL approval" has been type-tested and approved by Underwriter's Laboratory as meeting certain electrical and/or safety codes.

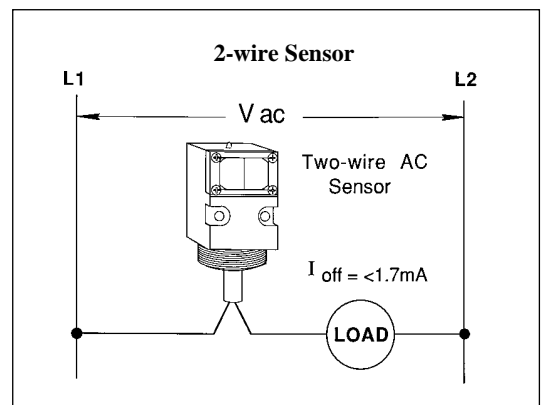
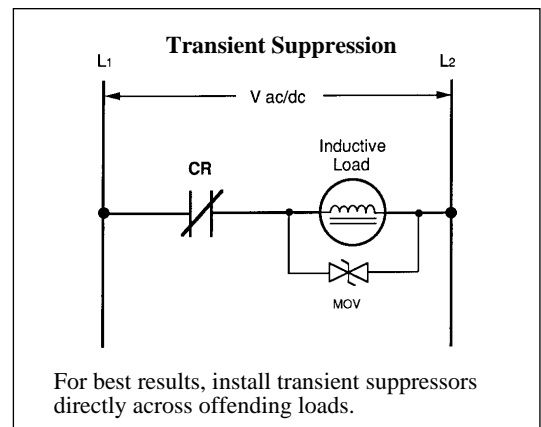

ultrasonic

Sound energy at frequencies just above the range of human hearing, above about 20 kHz. The use of ultrasound is of advantage in many sensing applications because of its ability to detect objects without regard to their reflectivity or translucency to light. Banner ULTRA-BEAM sensors are ultrasonic sensors.

upper cover

The removable component of a photoelectric sensor that includes the lensing. Upper covers are replaceable and, in some cases, are interchangeable for changes of sensing mode and/or sensing range.

UV (ultraviolet)

Invisible short wavelength light energy that lies immediately beyond the violet end of the color spectrum between approximately 100 and 380 nm. Some materials "fluoresce" and produce light of visible wavelengths when excited by UV energy. This re-radiation of visible light can be detected by a "UV sensor". See "LED".

VALOX®

A family of thermoplastic polyester materials manufactured by General Electric Company. Noted for its toughness, mechanical stability, and excellent insulating properties. Used for the housing of many Banner products, including OMNI-BEAM, MULTI-BEAM, MAXI-BEAM, VALU-BEAM, Q85 Series, MINI-BEAM, EZ-BEAM, Q19, ULTRA-BEAM, and MICRO-AMP.

voltage

The term used most often in place of "electromotive force", "potential", "potential difference", or "voltage drop" to designate the electric pressure that exists between two points and is capable of producing a flow of current when a closed circuit is connected between the two points.

voltage drop

The voltage that occurs across a solid-state device when its output is driving a load, or the voltage that exists across each element of a series circuit. The magnitude of the voltage drop is dependent upon the circuit demand of the load.

window (see "sensing window")

zener diode

A PN junction diode used as a voltage regulator because of its uniform breakdown characteristic when reverse biased. See the electronic symbol at the right.

