

MICRO-AMP® System

SP100AF Adjustable-field Sensor

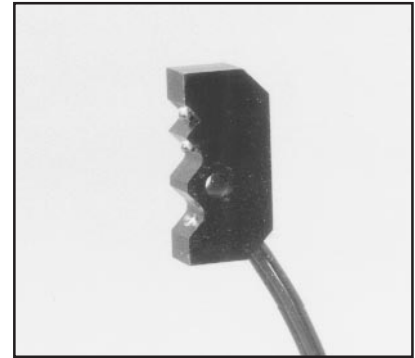

- Optical/Electrical design ensures an adjustable range limit, regardless of the surface reflectivity of the objects to be sensed
- Powerful infrared light source and modulated amplification provide reliable sensing of objects with low surface reflectivity
- Sensor response to background objects is completely suppressed
- Miniature size fits easily into tight areas of machines
- Works with a special version of Banner's MICRO-AMP® series amplifiers, model MA3AF



Model SP100AF is an adjustable-field convergent mode sensor that detects objects directly by reflection of light from the object's surface. Objects in the background are ignored, regardless of their surface reflectivity.

This sensing response feature makes the SP100AF an ideal choice for detecting a part or a surface that is only a small fraction of an inch in front of another surface. The SP100AF is highly reliable for semiconductor wafer sensing. Wafers of all reflectivities are sensed without system sensitivity adjustment. Other applications include cut-to-length control, double-thickness detection, and precision edgewise. The SP100AF is an excellent choice for precise position control (e.g. as a robotic end effector).

The SP100AF works in conjunction with Banner MICRO-AMP modulated amplifier model MA3AF. The model MA3AF is powered by +10 to 30V dc and uses a model RS8 socket. This amplifier has a 4-turn RANGE potentiometer for precise adjustment of the sensing distance.

The SP100AF has enough optical energy to reliably sense material of very low reflectivity such as nitride-coated semiconductor wafers. The typical peak signal point is 0.13 inch from the sensor face. The recommended operating range is .12 to .20 inches.

Theory of Operation

The SP100AF uses two LEDs that operate with the modulated amplifier in a differential mode. The LEDs are mechanically convergent with the receiver photoelement at two different distances from the sensor face. If photoelement (R) receives light that is emitted from the inner photoelement (E1), a positive-going pulse is produced which turns the output of the amplifier "on". When light from outer photoelement (E2) is received by photoelement (R), a negative-going pulse is produced which turns the amplifier "off".

A target is sensed whenever the amount of light from E1 reaching receiver R is equal to or greater than the amount of light from E2. The output of the amplifier is cut off as soon as the amount of light from E2 becomes greater than at E1. The location of this *crossover point* is adjustable via the 4-turn RANGE potentiometer and remains the same regardless of the target's reflectivity.

Reflections even from highly-polished mirror-like surfaces are ignored if the reflections originate from beyond the crossover point. Also, modulated LED design offers very high excess gain at the convergent point. As a result, even objects of very low reflectivity may be sensed.

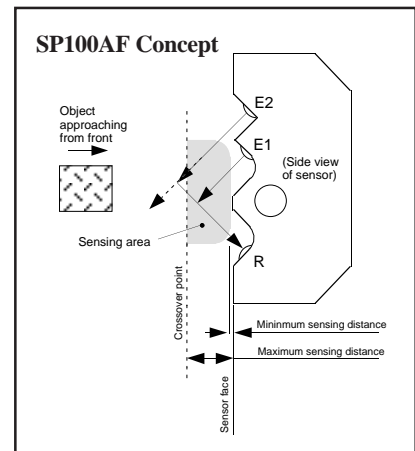

SP100AF Deviation Curve

Deviation is defined as the difference in the switch point between a 90% reflectance test card and a 10% reflectance test card. The switch point is measured by using the test cards as they approach the front of the sensor. Use the chart at the right to determine the maximum switch point deviation at various distances.

Example: When the range is adjusted for .12 inches off a 90% reflectance test card, the minimum range for a 10% reflectance test card is .11 inches. Distance (.12) minus Deviation (.01) = Minimum range (.11)

Maximum operating range of 10% reflectance test card is 0.1 to .20 inches. Maximum operating range of 90% reflectance test card is 0.1 to .40 inches.

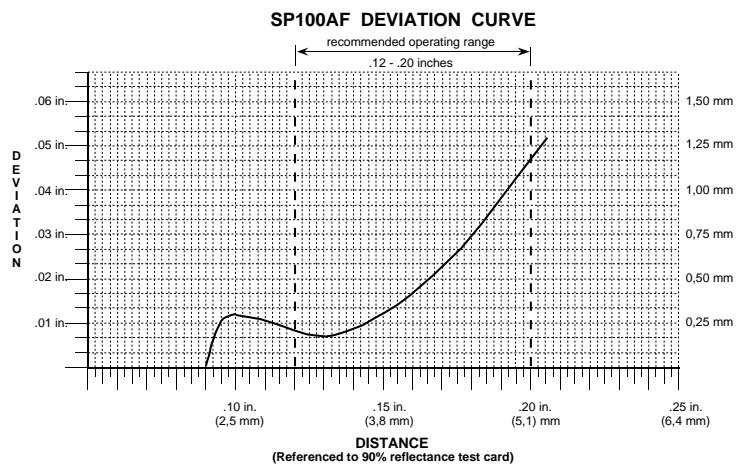

Specifications, model SP100AF

Crossover Point: .10 to .19 inch (2,5 to 4,8 mm);
.12 inch (3,0mm) recommended, referenced from sensor face.
Range adjustable via 4-turn potentiometer.

Response Speed: a function of the amplifier (see below)

Emitter characteristics: 2 infrared LEDs, 880nm

Construction: totally encapsulated, glass lenses.
Black Delrin® housing; NEMA 1, 3, 4, 12, and 13.

Operating Temperature: 0 to 70°C (+32 to 158°F)

Cable: supplied with 6 feet of 4-conductor ribbon cable.

Delrin® is a registered trademark of DuPont Co.

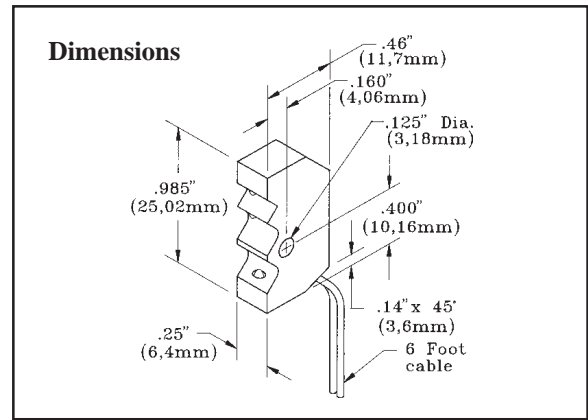

SP100AF Hookup to MICRO-AMP® MA3AF Amplifier

MICRO-AMP modulated amplifier model MA3AF is designed for use with the SP100AF sensor. Model MA3AF has the same specifications as standard MICRO-AMP model MA3, with the exceptions of response speed and sensor hookup.

Model MA3AF offers complementary *current sinking* outputs. Each output has sufficient capacity to switch small electromechanical devices, such as relays, and will directly interface logic inputs.

Connections are made using the optional RS8 socket and wiring base, or the MA3AF may be mounted directly to a PC board. The sensing system is powered by +10 to 30V dc. Power supply model MPS-15 is available, and includes its own board-mounted socket for the MA3AF and a built-in SPDT output relay.

Model MA3AF does not contain a sensitivity adjustment. The SP100AF's maximum range is adjustable via a four-turn potentiometer on top of the amplifier module. Circuitry is epoxy-encapsulated and protected by a tough molded VALOX® housing.

Additional information for model MA3AF may be obtained from the description of standard amplifier model MA3.

VALOX® is a registered trademark of General Electric Company

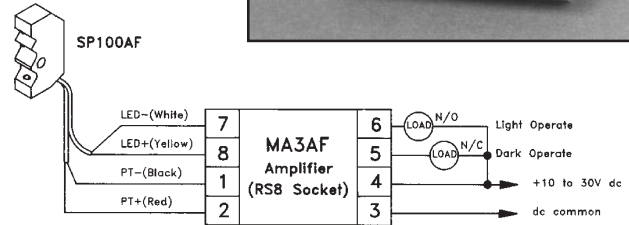
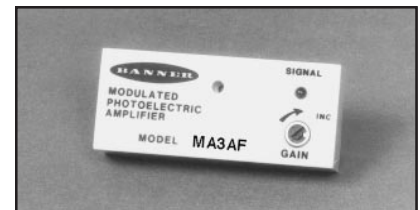

Specifications, MICRO-AMP MA3AF Amplifier

Power Supply Requirements: +10 to 30V dc at less than 20mA; 10% maximum ripple. Power may be obtained from Banner power supply model MPS-15, CP12C, CP12RC, or PS120-15.

Output Configuration: two open-collector NPN (current sinking) transistor solid-state switches, one normally open, one normally closed. 150mA maximum, each output.

Response speed: 10 milliseconds (typical)

Maximum Sensor Lead Length: 15 feet (4,5m)

Operating Temperature: 0 to 70°C (+32 to 158°F)



WARNING This photoelectric presence sensing system does NOT include the self-checking redundant circuitry necessary to allow its use in personnel safety applications. A sensor or module failure or malfunction can result in *either* an energized or a de-energized output condition.

Never use these products as sensing devices for personnel protection. Their use as safety devices may create an unsafe condition which could lead to serious injury or death.

Only MACHINE-GUARD and PERIMETER-GUARD Systems, and other systems so designated, are designed to meet OSHA and ANSI machine safety standards for point-of-operation guarding devices. No other Banner sensors or controls are designed to meet these standards, and they must NOT be used as sensing devices for personnel protection.

WARRANTY: Banner Engineering Corporation warrants its products to be free from defects for one year. Banner Engineering Corporation will repair or replace, free of charge, any product of its manufacture found to be defective at the time it is returned to the factory during the warranty period. This warranty does not cover damage or liability for the improper application of Banner products. This warranty is in lieu of any other warranty either expressed or implied.