

SureCross™ DX80 Quick Start Guide

A set-up guide for the SureCross DX80 wireless systems



Read these instructions before using your SureCross radios. Do not discard these instructions.

For more detailed information about installing and using your SureCross products, download and read the SureCross Wireless I/O Network Manual, p/n 132607.



p/n 128185 rev. H

⚠ WARNING . . . Not To Be Used for Personnel Protection

Never use these products as sensing devices for personnel protection. Doing so could lead to serious injury or death.

These devices do NOT include the self-checking redundant circuitry necessary to allow their use in personnel safety applications. A device failure or malfunction can cause either an energized or de-energized output condition. Consult your current Banner Safety Products catalog for safety products that meet OSHA, ANSI, and IEC standards for personnel protection.

SureCross Performance Models (900 MHz models only)

For SureCross Performance 2.4 GHz radios, skip to Step 3.

If the label on the face of your radio does not say Performance, skip to step 2 to activate extended addressing mode.



Step 1: Select 1 Watt or 250 mW Mode

By default, SureCross Performance 900 MHz radios are configured to transmit at 1 Watt. If you are mixing Performance models within the same network as non-Performance radios, you must operate in 250 mW mode.

1. Disconnect all radios from their power sources.
2. If you are using Performance radios within a DX80 network, move DIP switch 1 to the ON position to select 250 mW (DX80 compatibility mode).

Check the datasheet of your specific radio for any additional DIP switches applicable to your installation.

SureCross DX80 Models

If the label on the face of your radio does not say Performance, you will need to activate extended addressing mode.

Step 2: Activate Extended Addressing Mode

1. Disconnect all radios from their power sources.
2. Remove the top covers of the Gateway and all its Nodes.
3. Move DIP switch 1 to the ON position.

Check the datasheet of your specific radio for any additional DIP switches applicable to your installation.

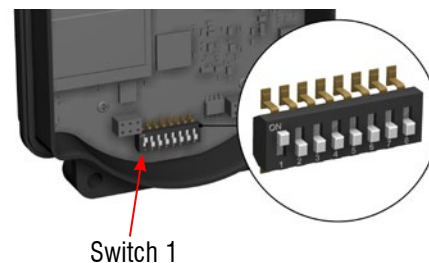

Switch 1

Step 3: Apply Power

1. Apply power to the Gateway by connecting 10–30V dc as shown in the wiring diagram.
2. Apply power to the Node by connecting 10–30V dc or the DX81 Battery Supply Module as shown.

5-pin Euro-style connector	"C" model terminals	Pigtail wire color	10-30V dc powered radios*	Solar or battery-powered radios**
----------------------------	---------------------	--------------------	---------------------------	-----------------------------------

1	V+	Brown	+10–30V dc	
3	V-	Blue	dc common (GND)	dc common (GND)
5	B+	Gray		3.6–5.5V dc

* Only use pin 5 (gray wire) for radios capable of being powered by solar or battery modules.

** For solar and battery-powered radios, do not apply more than 5.5V dc to pin 5 or the B+ terminal.

For more details, refer to your specific devices' datasheets.



Step 4: Bind the Radios to Form Networks

Binding Nodes to their Gateway ensures the Nodes only exchange data with that Gateway. A Gateway and its Nodes will not communicate until the Gateway teaches the Nodes the binding code. Verify the radios are at least two meters apart before binding the radios. For radios transmitting at 1 Watt, move the radios three meters apart. Bind the radios before installing them to their final locations.

On the Gateway

1. Triple click button 2 to enter binding mode.
The red LEDs flash. Any Node entering binding mode will bind to this Gateway.

On the Node

2. Triple click button 2 to enter binding mode.
The Node enters binding mode and locates the Gateway also in binding mode. After the Node is bound, the LEDs are both solid red for a few seconds. The Node cycles its power and enters RUN mode.
3. Use both rotary dials to assign a Node address (device ID) between 01 and 47. The left rotary dial represents the tens digit (0-4) and the right dial represents the ones digit (0-9) of the Node address.
4. Repeat steps 2 and 3 for each additional Node that needs to communicate to that Gateway.

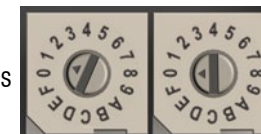

On the Gateway

5. Single click either button 1 or button 2 to exit binding mode. The Gateway cycles power and enters RUN mode.

Step 5: Verify Communications

Status	Gateway		Node	
	LED 1	LED 2	LED 1	LED 2
Power ON or RF Link OK	● Green ON		● Green flash (1 per sec)	
System Error	● Red flash	● Red flash	● Red flash	● Red flash
RF Link Error				● Red flash (1 per 3 sec)
Modbus Communication Active		● Yellow flash		
Modbus Communication Error		● Red flash		

Until communication is established with the Gateway, the Node's LED 2 flashes red. When communication is established, the Node's LED 1 flashes green.

When testing the Gateway and Node before installation, verify the Gateway and Node are at least two meters apart or the communications may fail.

Step 6: Conduct a Site Survey Using the Menu System

A site survey analyzes the radio communications link between the Gateway and a selected Node and reports the number of missed packets that required a retry.

Use the Gateway to initiate a site survey analysis.

1. Remove the rotary dial access cover.
2. Set the Gateway's rotary dials to the Node address you want to survey. For example, to analyze Node 1's signal, change the Gateway's left rotary dial to 0 and its right rotary dial to 1. (To analyze Node 12's signal, change the Gateway's left rotary dial to 1 and its right rotary dial to 2.)
3. Single-click button 1 to scroll across the menu levels until reaching the Site Survey (SITE) menu.
4. Single-click button 2 to enter the Site Survey menu.
5. Single-click button 2 to begin conducting a Site Survey with the selected Node.
The Gateway counts the data packets received from the Node.
6. Examine reception readings (M, R, Y, G). M displays the percent of missed packets while R, Y, and G display the percentage of received packets at a given signal strengths: R = RED marginal signal; Y = YELLOW good signal; G = GREEN excellent signal
7. To end the Site Survey, double-click button 2.
8. Change the Gateway's right rotary dial back to 0.
9. Double-click button 2 to move back to the top level menu.
10. Single-click button 1 to return to RUN mode.
11. Install the rotary dial access cover, referring to the Installation section of the manual to create an IP67 seal.

Step 7: Installing Your SureCross Radios

For most outdoor applications, we recommend installing your SureCross devices inside a secondary enclosure. If not using an enclosure, mount the DX80 where rain or snow will drain away from the unit.

To minimize the damaging effects of ultra-violet radiation, avoid mounting the Gateway or Node facing intense direct sunlight.



User Configuration Tool (UCT)

The User Configuration Tool (UCT) offers an easy way to link I/O points in your wireless network, view I/O register values graphically, and set system communication parameters when a host system is not part of the wireless network.

The User Configuration Tool requires the USB to RS-485 converter cable, BWA-UCT-900.



DX70, DX80, and Performance Mounting Template

The gray-shaded section represents the DX80...C housings' removable terminal headers.

Only if you are using the printed copy provided by Banner can this be used as a mounting template.

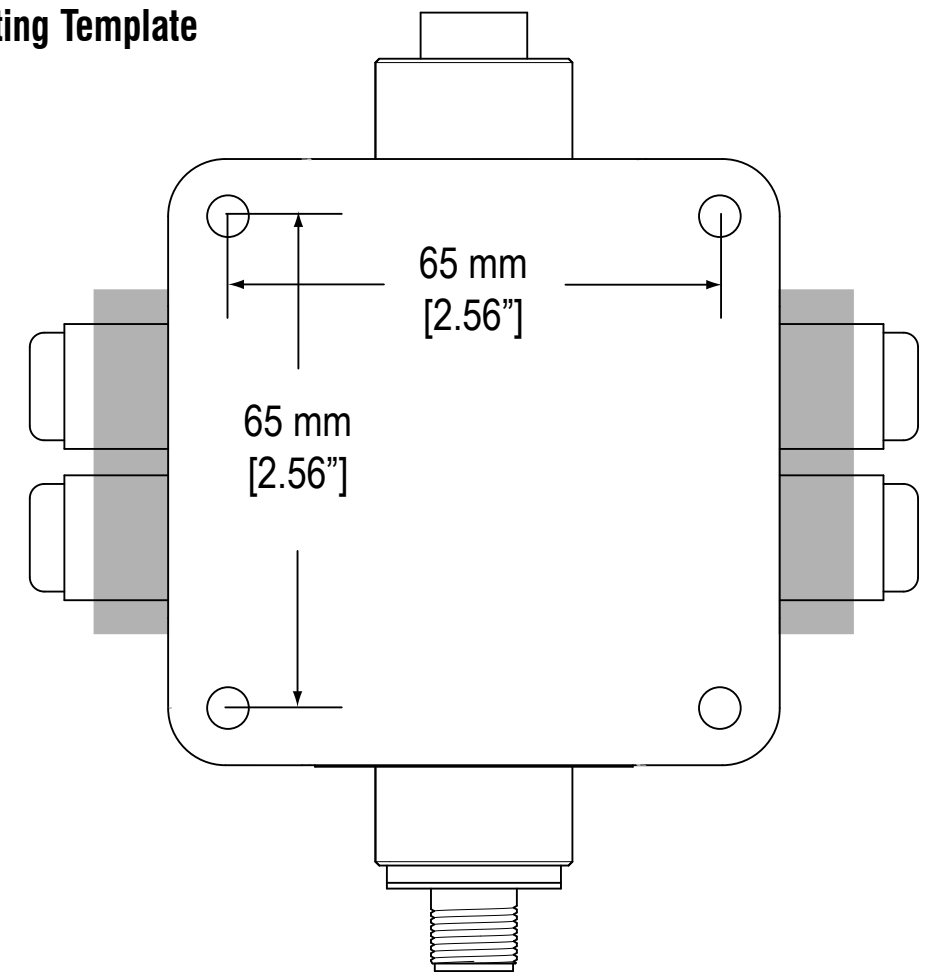

Banner Engineering Corp. warrants its products to be free from defects in material and workmanship for one year following the date of shipment. Banner Engineering Corp. will repair or replace, free of charge, any product of its manufacture which, at the time it is returned to the factory, is found to have been defective during the warranty period. This warranty does not cover damage or liability for misuse, abuse, or the improper application of the Banner product.

THIS LIMITED WARRANTY IS EXCLUSIVE AND IN LIEU OF ALL OTHER WARRANTIES WHETHER EXPRESS OR IMPLIED (INCLUDING, WITHOUT LIMITATION, ANY WARRANTY OF MERCHANTABILITY OR FITNESS FOR A PARTICULAR PURPOSE), AND WHETHER ARISING UNDER COURSE OF PERFORMANCE, COURSE OF DEALING OR TRADE USAGE.

This Warranty is exclusive and limited to repair or, at the discretion of Banner Engineering Corp., replacement. **IN NO EVENT SHALL BANNER ENGINEERING CORP. BE LIABLE TO BUYER OR ANY OTHER PERSON OR ENTITY FOR ANY EXTRA COSTS, EXPENSES, LOSSES, LOSS OF PROFITS, OR ANY INCIDENTAL, CONSEQUENTIAL OR SPECIAL DAMAGES RESULTING FROM ANY PRODUCT DEFECT OR FROM THE USE OR INABILITY TO USE THE PRODUCT, WHETHER ARISING IN CONTRACT OR WARRANTY, STATUTE, TORT, STRICT LIABILITY, NEGLIGENCE, OR OTHERWISE.**

Banner Engineering Corp. reserves the right to change, modify or improve the design of the product without assuming any obligations or liabilities relating to any product previously manufactured by Banner Engineering Corp.

The manufacturer does not take responsibility for the violation of any warning listed in this document.

CAUTION. Make no modifications to this product. Any modifications to this product not expressly approved by Banner Engineering could void the user's authority to operate the product. Contact the Factory for more information.

Lightning Arrestors/Surge Protection. Always use lightning arrestors/surge protection with all remote antenna systems to avoid invalidating the Banner Engineering Corp. warranty. No surge protector can absorb all lightning strikes. Do not touch the SureCross device or any equipment connected to the SureCross device during a thunderstorm.

All specifications published in this document are subject to change. Banner reserves the right to modify the specifications of products, prior to their order, without notice. Banner Engineering reserves the right to update or change documentation at any time. For the most recent version of any documentation, please refer to our website: www.bannerengineering.com. © 2009-2011 Banner Engineering Corp. All rights reserved.

For additional information, including installation and setup, weatherproofing, device menu maps, troubleshooting, and a list of accessories, please refer to the SureCross™ DX80 Wireless I/O Network product manual, Banner p/n [132607](http://www.bannerengineering.com).