





Additional information on this product is immediately available online at www.bannerengineering.com/121902

For further assistance, contact a Banner Engineering Applications Engineer at (763) 544-3164 or (888) 373-6767.



Models

Models		Construction	Connector*	LED Function**	Inputs								
	M18GRY2PQ	Nickel-plated brass housing, M18x1 thread; thermoplastic diffuser.	5-pin Euro-style integral QD NOTE: Pin 5 not used; connects to 4-wire QD cable. If cables other than those specified on page 3 are used, use a 5-pin mating cable.	Choose Red, Yellow, or Green ON, flashing, or rotating (depending on hookup)	PNP (Sourcing)								
	M18GRY2NQ	Fully encapsulated IP67			NPN (Sinking)								
	T30GRY2PQ	Thermoplastic polyester housing, thermoplastic diffuser.			5-pin Euro-style integral QD NOTE: Pin 5 not used; connects to 4-wire QD cable. If cables other than those specified on page 3 are used, use a 5-pin mating cable.	Choose Red, Yellow, or Green ON, flashing, or rotating (depending on hookup)	PNP (Sourcing)						
	T30GRY2NQ	Fully encapsulated IP67					NPN (Sinking)						
	K50LGRY2PQ	30 mm threaded polycarbonate base, translucent polycarbonate dome.					5-pin Euro-style integral QD NOTE: Pin 5 not used; connects to 4-wire QD cable. If cables other than those specified on page 3 are used, use a 5-pin mating cable.	Choose Red, Yellow, or Green ON, flashing, or rotating (depending on hookup)	PNP (Sourcing)				
	K50LGRY2NQ	Fully encapsulated IP67							NPN (Sinking)				
	K50FLGRY2PQ	Polycarbonate base, translucent polycarbonate dome.							5-pin Euro-style integral QD NOTE: Pin 5 not used; connects to 4-wire QD cable. If cables other than those specified on page 3 are used, use a 5-pin mating cable.	Choose Red, Yellow, or Green ON, flashing, or rotating (depending on hookup)	PNP (Sourcing)		
	K50FLGRY2NQ	Fully encapsulated IP67									NPN (Sinking)		
	K80LGRY2PQ	ABS and polycarbonate base, translucent polycarbonate dome.									5-pin Euro-style integral QD NOTE: Pin 5 not used; connects to 4-wire QD cable. If cables other than those specified on page 3 are used, use a 5-pin mating cable.	Choose Red, Yellow, or Green ON, flashing, or rotating (depending on hookup)	PNP (Sourcing)
	K80LGRY2NQ	Electronics fully encapsulated IP67											NPN (Sinking)

* **K80L Models:** Standard 5-pin Euro integral QD connector models are listed (mating cable required; see page 3). For terminal-wired model, omit suffix "Q" (e.g., "K80LGRY2P").

Other Models: Standard integral QD models are listed (mating cable required; see reverse). For 2 m (6.5') cable model, omit suffix "Q" from model number (e.g., M18GRY2P). For 150 mm (6") PVC pigtail with 5-pin Euro QD connector, replace suffix "Q" with "QP" (e.g., M18GRY2PQP).

** Contact Factory for other colors/color combinations, including: blue, white, orange.

EZ-LIGHT™ – 3-Color, 7-Function

Specifications

Supply Voltage and Current

M18 Models: 10 to 30V dc @ 40 mA max.

T30 Models: 10 to 30V dc @ 50 mA max.

K50L, K50FL and K80L Models: 18 to 30V dc @ 50 mA max.

Indicators

Entire translucent diffuser or dome provides indication.

LEDs are independently selected: Green, Red, Yellow, ON steady or flashing.

For other colors/combinations, contact Factory for availability.

Input Response Time

Indicator ON: 250 ms (max.)

Indicator OFF: 10 ms (max.)

Indicator Flash Rate

Single Color: 1 second flash rate (500 ms ON)

Three Color: 1.5 second rotation rate (500 ms per color)

Environmental Rating

IEC IP67

K80L has encapsulated electronics only; other models fully encapsulated

Connections

K80L Models: 5-pin Euro-style integral QD (Q) standard. Terminal-wired models available for use with bulk cable; compression fitting optional. Contact Factory for cable information.

Other Models: 5-pin Euro-style integral QD (Q); 6" pigtail QD (QP), (do not use center pin 5); or 5-wire, 2 m (6.5') integral cable

Operating Conditions

Temperature: -40° to +50° C (-40° to +122° F)

Dimensions

M18 Models

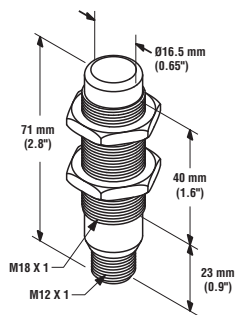

T30 Models

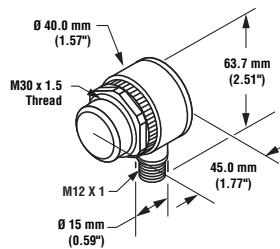

K50L Models

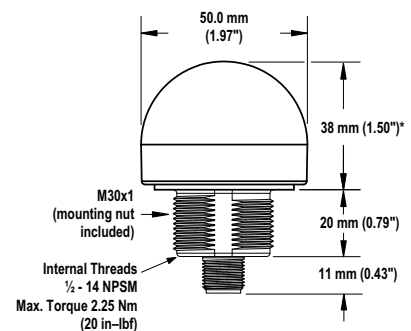

K50FL Models

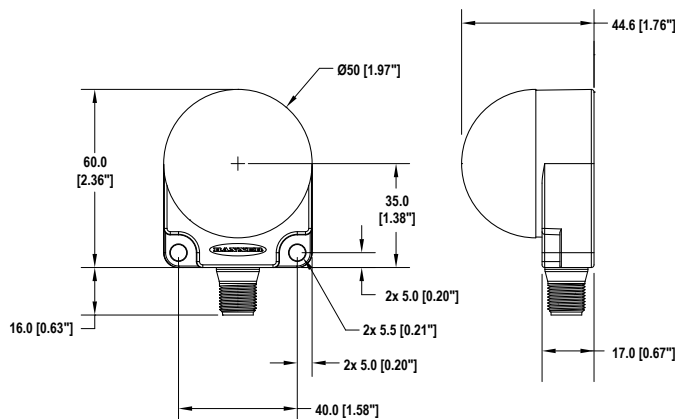

K80L Models

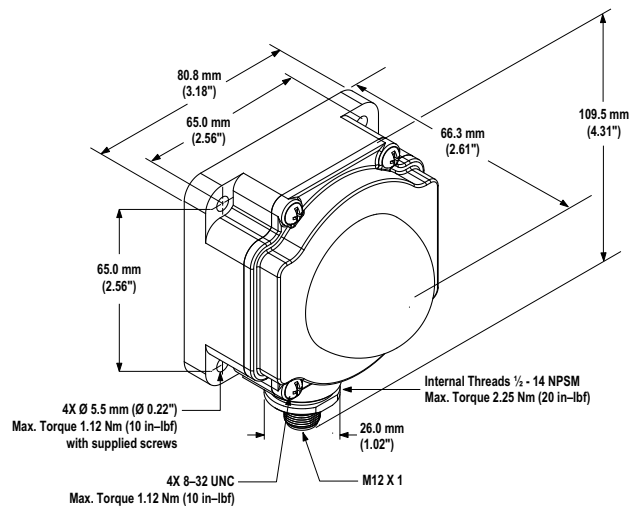

Hookups

Select from 7 operating schemes, depending on hookup:

LED Function	PNP Models				NPN Models			
	Brown Wire	White Wire	Black Wire	Blue Wire	Blue Wire	White Wire	Black Wire	Brown Wire
Red ON	+V dc			0V dc	0V dc			+V dc
Red Flashing	+V dc		+V dc	0V dc	0V dc		0V dc	+V dc
Yellow ON		+V dc		0V dc		0V dc		+V dc
Yellow Flashing	+V dc	+V dc		0V dc	0V dc	0V dc		+V dc
Green ON			+V dc	0V dc			0V dc	+V dc
Green Flashing		+V dc	+V dc	0V dc		0V dc	0V dc	+V dc
Rotating Red-Green-Yellow	+V dc	+V dc	+V dc	0V dc	0V dc	0V dc	0V dc	+V dc

PNP Models

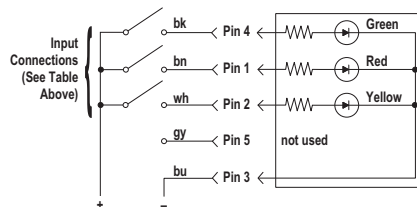

NPN Models

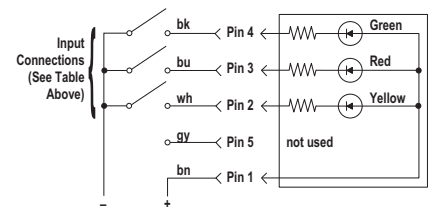

Only QD hookups are shown; cabled hookups are functionally identical.

Quick-Disconnect (QD) Cables

Style	Model	Length	Dimensions	Pinout
4-pin Euro-style straight	MQDC-406 MQDC-415 MQDC-430	2 m (6.5') 5 m (15') 9 m (30')		<p>NOTE: If cables other than these are used, use a 5-pin mating cable</p>
4-pin Euro-style right-angle	MQDC-406RA MQDC-415RA MQDC-430RA	2 m (6.5') 5 m (15') 9 m (30')		

Bulk cable for terminal-wired K80L models: Contact Factory.

EZ-LIGHT™ – 3-Color, 7-Function

Accessory Mounting Brackets*

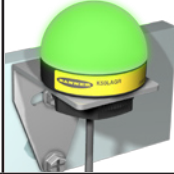
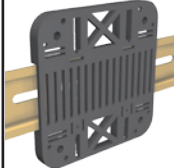
SMB18A	<ul style="list-style-type: none"> • For use with M18 and T18 models or base-mount T30 models • 12-gauge, stainless steel, right-angle bracket, curved mounting slot for adjustable orientation • Clearance for M4 (#8) hardware 	Other available 18 mm dia. brackets: SMB1815SF SMB18Q SMB18SF SMB312PD SMBAMS18RA SMBAMS18P	
SMB30A	<ul style="list-style-type: none"> • For use with T30 models or base-mount K50L models • 30 mm 12-gauge, 304 stainless steel, right-angle mounting bracket, curved mounting slot for adjustable orientation • Clearance for M5 (#10) hardware 	Other available 30 mm dia. brackets: SMBAMS30RA SMBAMS30P SMB30SC SMB30SC SMB30MM SMB3018SC	
SMBDX80D	<ul style="list-style-type: none"> • DIN-mount bracket for K80L models • Hardware included to mount to K80L housing • ABS 		

* K50FL models include a 48 mm (1.9") circular velcro mounting kit for easy mounting with no additional hardware

Additional information on this product is immediately available online at www.bannerengineering.com/121902

For further assistance, contact a Banner Engineering Applications Engineer at (763) 544-3164 or (888) 373-6767.



WARRANTY: Banner Engineering Corp. warrants its products to be free from defects for one year. Banner Engineering Corp. will repair or replace, free of charge, any product of its manufacture found to be defective at the time it is returned to the factory during the warranty period. This warranty does not cover damage or liability for the improper application of Banner products. This warranty is in lieu of any other warranty either expressed or implied.