



LED..R..M Series Ring Lights

LED Ring Lights (in two sizes) for use with PresencePLUS® P4 sensors



Features

- Low-cost, compact and standard sized ring lights for PresencePLUS® P4 sensor. See Banner's Web site (www.bannerengineering.com) for a complete lighting tutorial.
- Two sizes available
- Continuous or strobed operation is selectable via sensor software.
- Solid-state LED matrix
- Direct connection to PresencePLUS P4 (if sensor is powered by 24V dc)
- Mounts directly to PresencePLUS P4 sensor using included hardware

Models

Models		Color	Ambient Light Filter Kit	Polarizing Filter Kit	
62 x 62 mm	80 x 80 mm			62 x 62 mm	80 x 80 mm
LEDIR62X62M	LEDIR80X80M	Infrared, 940 nm	FLTI	—	—
LEDRR62X62M	LEDRR80X80M	Visible Red, 630 nm	FLTR (included with LEDRRPFK)	LEDRRPFKS	LEDRRPFK
LEDWR62X62M	LEDWR80X80M	White, All Visible	FLTB or FLTG		
LEDBR62X62M	LEDBR80X80M	Blue, 464 to 475 nm	FLTB		
LEDGR62X62M	LEDGR80X80M	Green, 520 to 540 nm	FLTG		

Specifications

Light Source	LED, see Models table above for wave lengths
Illumination	High-intensity ring light
Supply Voltage and Current	Voltage supplied by PresencePLUS P4 sensors, if operating at 24V dc (see sensor manual). 62 x 62 Models: Infrared — 24V dc @ 100 mA max. 80 x 80 Models: 24V dc @ 250 mA max. All other colors — 24V dc @ 130 mA max.
Connections	300 mm (12") attached pigtail with 3-wire, 8 mm male Pico-style connector
Construction	Low-carbon steel with black zinc plating, acrylic window
Useful Life	10,000 hours (LED ON time). When operated within specifications, output will decrease less than 30% after 10,000 hours and less than 50% (less than 40% for red and IR models) after 20,000 hours.
Operating Conditions	Temperature: 0° to +50° C (+32° to 122° F) Relative humidity: 90% at 50° C (non-condensing) max.
Cleaning Instructions	Regularly remove any dust, dirt, or fingerprints from the light source. 1. Blow off dust using anti-static compressed air. 2. If necessary, use a lens cloth and lens cleaner or window cleaner to wipe off remaining debris. Do not use any other chemicals for cleaning.

LED..R..M Series Ring Lights

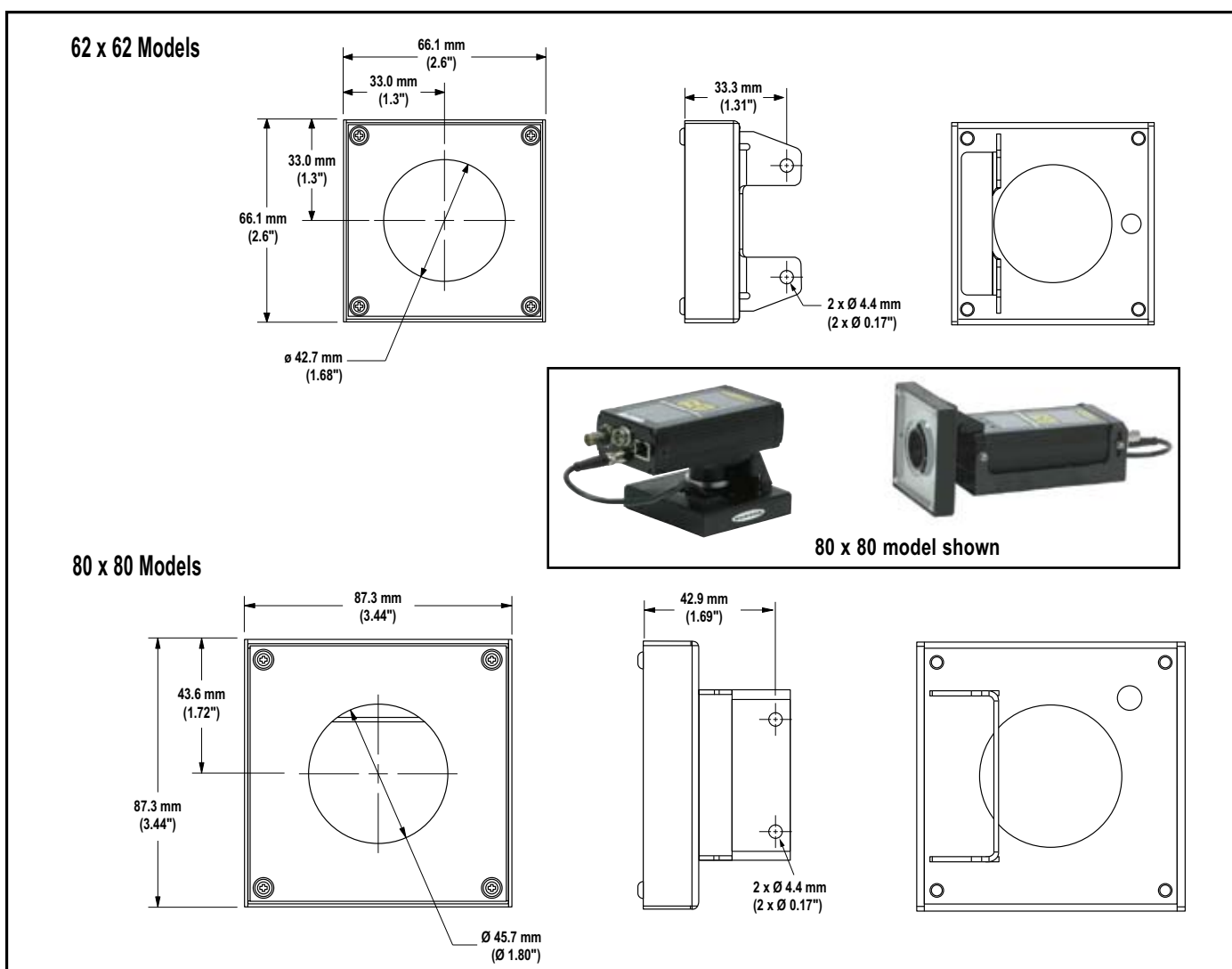

Figure 1. Ring light dimensions

Installing the Ring Light

The ring light bracket attaches to the top of the *PresencePLUS P4* lens block, using the hardware kit provided.

NOTE: Before installing this ring light it is recommended that an ambient light filter be installed behind the lens. The filter improves image quality by reducing unwanted ambient light.

Sensing Shiny Surfaces

To eliminate direct reflections without using polarizing filters, angle the sensor approximately 15° (or more) from perpendicular to a shiny surface.

Polarizing Kit

If it is necessary to mount the camera at a 90° angle to a shiny surface, the LEDRRPFK(S) polarizing filter kit provides filters for both the LED ring light and sensor to reduce the negative effects of strong, direct light reflections. The red filter kit (FLTR) is included with the polarizing kit. When light colors other than red are used, discard the red filter in the polarizing kit and use the proper filter listed on page 1. The polarizing filters reduce the amount of light returned to the sensor.

WARRANTY: Banner Engineering Corp. warrants its products to be free from defects for one year. Banner Engineering Corp. will repair or replace, free of charge, any product of its manufacture found to be defective at the time it is returned to the factory during the warranty period. This warranty does not cover damage or liability for the improper application of Banner products. This warranty is in lieu of any other warranty either expressed or implied.

BANNER[®]
more sensors, more solutions