

Additional information on this product is immediately available online at www.bannerengineering.com/116162



View or download additional information, including excess gain curves, beam patterns and accessories.
For further assistance, contact a Banner Engineering Applications Engineer at (763) 544-3164 or (888) 373-6767.



Cabled Emitters

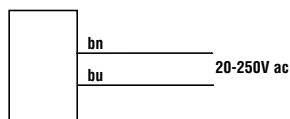

QD Emitters (4-pin Micro-Style)

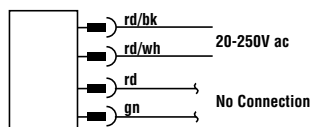

All Other Cabled Models

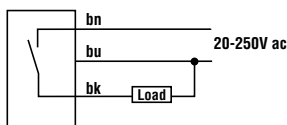

All Other QD Models (4-pin Micro-Style)

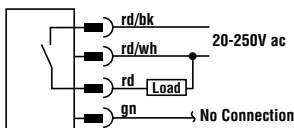

Sensing Mode		Range	LED	Output	Model*
	Opposed	60 m (200')	Infrared 950 nm	-	T303E
				LO	T30AW3R
				DO	T30RW3R
	Polarized Retro-reflective	6 m (20')	Visible Red 680 nm	LO	T30AW3LP
				DO	T30RW3LP
	Fixed Field	200 mm (8") cutoff	Infrared 880 nm	LO	T30AW3FF200
		400 mm (16") cutoff		DO	T30RW3FF200
				LO	T30AW3FF400
		600 mm (24") cutoff		DO	T30RW3FF400
				LO	T30AW3FF600
		DO		T30RW3FF600	

* Standard 2 m (6.5') cable models are listed.

• **9 m (30') cable:** add suffix "W/30" (e.g., T303E W/30).

• **4-pin Micro-style QD models:** add suffix "Q1" (e.g., T303EQ1). A model with a QD connector requires a mating cable.

Dimensions

Cabled Models

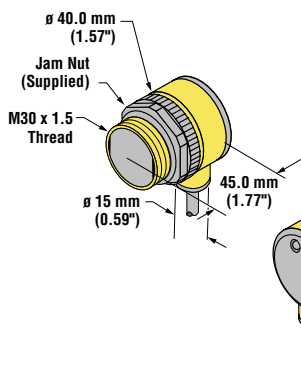

QD Models

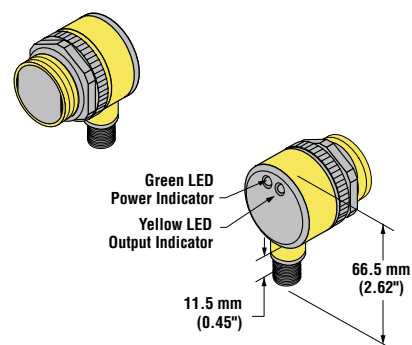

WARNING . . . Not To Be Used for Personnel Protection

Never use these products as sensing devices for personnel protection. Doing so could lead to serious injury or death.

These sensors do NOT include the self-checking redundant circuitry necessary to allow their use in personnel safety applications. A sensor failure or malfunction can cause either an energized or de-energized sensor output condition. Consult your current Banner Safety Products catalog for safety products which meet OSHA, ANSI and IEC standards for personnel protection.

EZ BEAM T30 Sensors – ac-Voltage Series

Specifications

Supply Voltage and Current

20 to 250V ac (50/60 Hz). Average current: 20 mA
Peak current: 200 mA at 20V ac, 500 mA at 120V ac, 750 mA at 250V ac

Supply Protection Circuitry

Protected against transient voltages

Output Configuration

SPST solid-state ac switch; Three-wire hookup; Choose light operate or dark operate models

Light Operate: Output conducts when sensor sees its own (or the emitter's) modulated light

Dark Operate: Output conducts when the sensor sees dark

Output Rating

300 mA maximum (continuous);

Fixed-Field Models: derate 5 mA/°C above +50°C (+122°F)

Inrush Capability 1 amp for 20 milliseconds, non-repetitive

OFF-state leakage current: < 100 microamps

ON-state saturation voltage: 3V at 300 mA ac; 2V at 15 mA ac

Output Protection Circuitry

Protected against false pulse on power-up

Output Response Time

Opposed Mode: 16 milliseconds ON, 8 milliseconds OFF

Other Models: 16 milliseconds ON and OFF

NOTE: 100 millisecond delay on power-up

Repeatability

Opposed Mode: 2 milliseconds

Other Models: 4 milliseconds

Repeatability and response are independent of signal strength.

Indicators

Two LEDs (Green and Yellow)

Green ON steady: power to sensor is ON

Yellow ON steady: sensor sees light

Yellow flashing: excess gain marginal (1 to 1.5x) in light condition

Construction

PBT polyester housing; polycarbonate (opposed mode) or acrylic lens

Environmental Rating

Leakproof design rated NEMA 6P, DIN 40050 (IP69K)

Connections

2 m (6.5') attached cable, or 4-pin Micro-style quick-disconnect fitting

Operating Conditions

Temperature: -40° to +70°C (-40° to +158°F);

Maximum relative humidity: 90% at 50°C (non-condensing)

Vibration and Mechanical Shock

All models meet Mil. Std. 202F requirements. Method 201A (Vibration; frequency 10 to 60 Hz, max., double amplitude 0.06" acceleration 10G). Method 213B conditions H&I (Shock: 75G with unit operating; 100G for non-operation)

Certifications

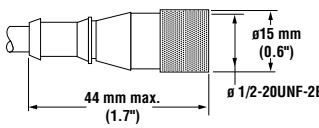
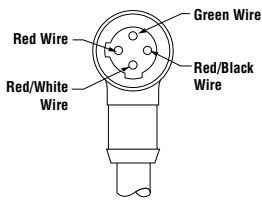
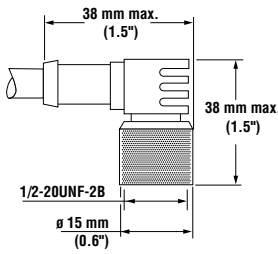

Quick-Disconnect (QD) Cables

Style	Model	Length	Dimensions	Pinout
4-pin Micro-style Straight	MQAC-406 MQAC-415 MQAC-430	2 m (6.5') 5 m (15') 9 m (30')		
4-pin Micro-style Right-angle	MQAC-406RA MQAC-415RA MQAC-430RA	2 m (6.5') 5 m (15') 9 m (30')		

Additional information on this product is immediately available online at www.bannerengineering.com/116162



View or download additional information, including excess gain curves, beam patterns and accessories.
For further assistance, contact a Banner Engineering Applications Engineer at (763) 544-3164 or (888) 373-6767.



WARRANTY: Banner Engineering Corp. warrants its products to be free from defects for one year. Banner Engineering Corp. will repair or replace, free of charge, any product of its manufacture found to be defective at the time it is returned to the factory during the warranty period. This warranty does not cover damage or liability for the improper application of Banner products. This warranty is in lieu of any other warranty either expressed or implied.