

# Model HFFW5100 Fluorescent Ring Light

The Model HFFW5100 fluorescent ring light operates at over 25 kHz to provide flicker-free illumination. The Model HFFW5100 offers 360° of uniform, shadow-free light. The polycarbonate plastic housing stays cool to the touch and does not radiate heat that could affect objects in the illumination field.

## Installation

1. Remove the lens from the PresencePLUS sensor.  
NOTE: When using this, or any non-red light source, remove the red filter that is preinstalled behind the sensor lens.
2. Slide the HFFW5100 fluorescent ring light onto the lens mount. Lock the light in place by tightening the three Allen head set screws on the light with a 1/16" Allen wrench (supplied).
3. Reinstall the lens.
4. Plug the ballast into an AC receptacle.
5. Turn the ON-OFF switch to ON.

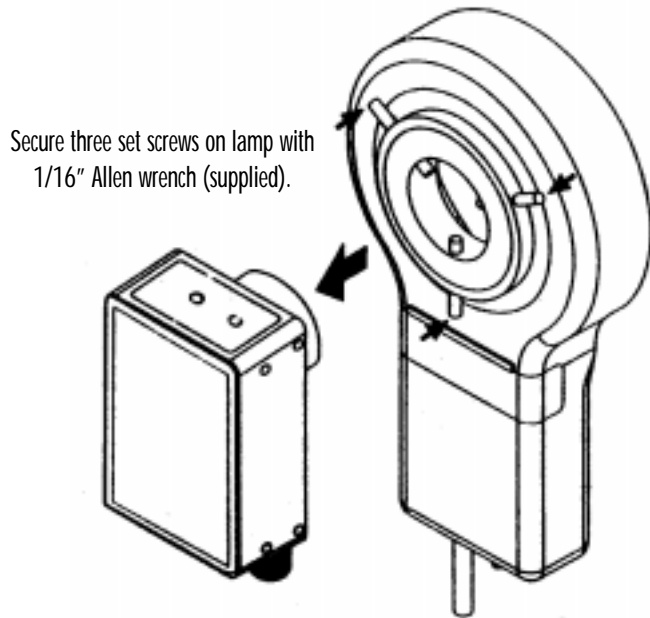

Installing the Fluorescent Ringlight

## Lamp Replacement

Replace the lamp in the HFFW5100 light source every 7,000 hours of operation.

1. Disconnect the power and all other cables from the Banner sensor.
2. Shut off power to the HFFW5100 and remove the ballast from the AC power outlet.
3. Loosen the three set screws on the light source using a 1/16" Allen wrench.
4. Remove cover from HFFW5100 by first removing the Phillips screw.
5. Remove and replace bulb.
6. Reassemble.

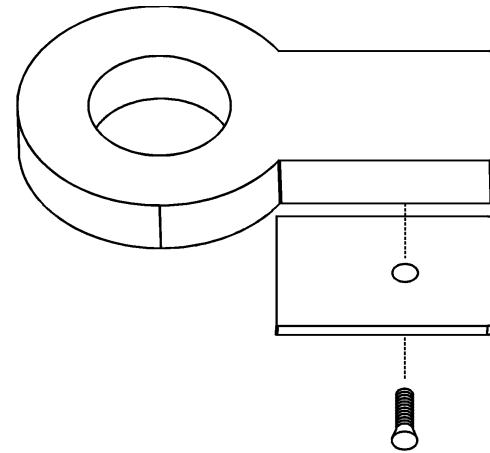

### CAUTIONS:

1. Disconnect power before servicing.
2. For service or technical assistance, please contact Banner Engineering at 763-544-3164.



P/N 115969

## Specifications:

### Environmental Conditions:

Operating Temp. Range:	32 to 104°F (0 to 40°)
Pollution Degree:	2
Humidity Range:	0 to 80%, non-condensing

### Electrical Specifications:

Power Input Voltage (AC):	120 VAC (60 Hz)
Lamp Input Power:	14W, maximum
Lamp Frequency:	25 kHz
Lamp Life:	7000 hours
Color Temperature:	5100K

### Unit is Overvoltage Category II:

Local level, appliances, portable equipment, etc. with smaller transient overvoltages than Overvoltage Category III.

### Dimensions of Circular Lamp Housings:

Depth:	1.01" (25.65mm)
Width:	2.13" (54.1mm)
Length:	6.77" (171.96mm)
Outside Diameter:	3.84" (97.54mm)
Inside Diameter:	1.25" (31.75mm)

9714 10th Avenue North  
Minneapolis, MN 55441  
Phone: 763-544-3164  
Fax: 763-544-3213  
<http://www.bannerengineering.com>  
E-mail: [sensors@baneng.com](mailto:sensors@baneng.com)



## Model HFFW5100

High Frequency Fluorescent Ring Light

White Light, 120 VAC

INSTRUCTION MANUAL

