

Models

Model	For Use with Area Light or Backlight Models
LEDAPFK	LED..80X80 LED..70X70
LEDAPFKS	LED..62X62
LEDAPFKSCS	LED..62X62 with CS-mount lens camera

Installing the Polarizing Filter Kit

Each Polarizing Filter Kit provides polarizing filters for both the light source and the PresencePLUS camera. Optional color filters are available separately.

1. Remove and set aside the four Phillips screws on the light's window (Figure 1).
2. Remove the protective plastic covering from both sides of each filter.
3. Place the polarizing filter into the light on top of the window. Secure with the four Phillips screws.
4. The camera filters install behind the lens (Figure 2). Remove the lens and insert the optional color filter first, if used, then the polarizing filter. Install the retaining ring, using the tool supplied with this filter kit.

NOTE: Take care not to fingerprint the filters. If necessary, carefully clean the filters using only lens or window cleaner.

5. Reinstall the lens.

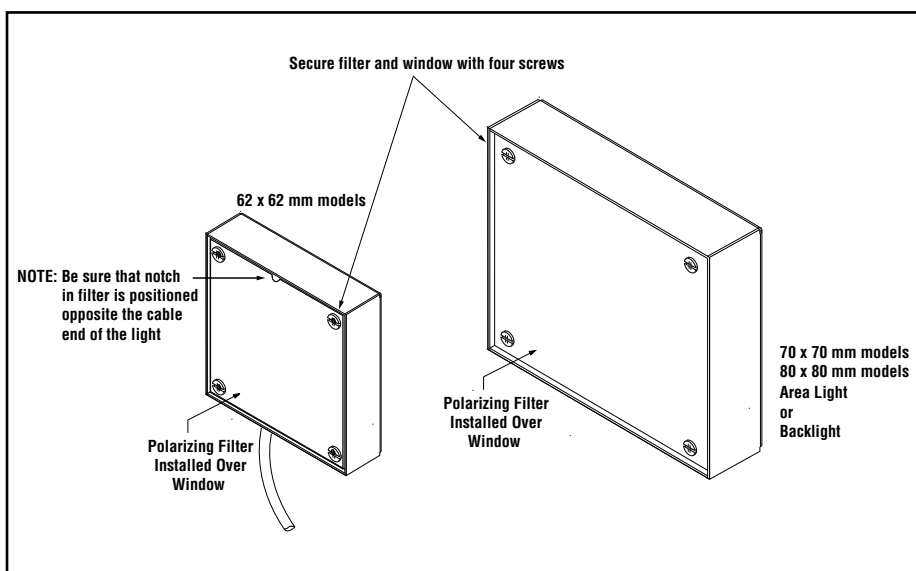

Figure 1. Installing the Polarizing Filter on the Light

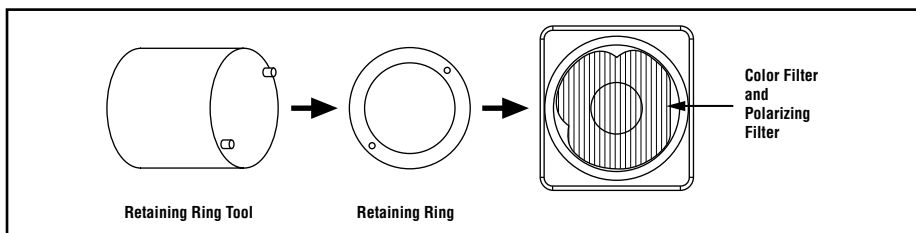

Figure 2. Installing the Color Filter (if used) and Polarizing Filter on the Camera