



PICO-GUARD Fiber Optic Safety Interlock Switches

Models SFI-S1R and SFI-S1L

These fiber optic safety switches are intended to be used with PICO-GUARD series controllers in personnel-safety and equipment-protection applications.



Features and Description

- Compact, non-contact, easy-to-install means of interlocking doors, guards, gates, and covers
- In-line lens housing
- Simple, quick means of connecting and disconnecting the fiber
- For use with Banner 2.2 mm OD plastic fiber optic cable (1 mm core)
- Designed to meet Safety Category 4 applications with one switch pair per guard (per ISO13849-1)
- Impact-resistant polycarbonate plastic construction
- Environmental rating of IEC IP65 (NEMA 4, 13)
- Attenuator available (see p/n 109910) for reducing excess gain in short-run applications
- Splice available for easy connection of two fiber sections (see p/n 109910)

Refer to PICO-GUARD Controller Manual (p/n 69761) and PICO-GUARD Application and Design Guide (p/n 69763) for complete installation and operation information.



Important ... Read this Section!

Information for use is found within each PICO-GUARD Fiber Optic Safety Interlock Switch data sheet, the Controller installation manual, and the Application and Design Guide. Please direct questions regarding the use or installation of this system to the factory applications department at the telephone numbers or address on page 4.



Caution ... Appropriate Applications

In addition to the limitations listed in the documents mentioned above (page 2), **use of Banner PICO-GUARD Fiber Optic Safety Interlock Switches is generally not allowed for:**

- Individual beam(s) in an optical grid for presence-sensing safeguarding (e.g., perimeter guarding).
- Linear (parallel) movement along the optical axis (see the Application and Design Guide).
- Machinery with long stopping time, without guard-locking mechanism.



WARNING . . . Fiber Optic Safety Interlock Switches, by themselves, are not a stand-alone guarding device.

They must be appropriately installed and interfaced with a PICO-GUARD Fiber Optic Safety System controller to be an effective safeguard. See the PICO-GUARD Controller Installation Manual, and the PICO-GUARD Application and Design Guide for **complete installation instructions**. Extreme care is urged to ensure that all installation and maintenance instructions contained in all manuals are followed. **The user is responsible for ensuring that all local, state, and national laws, rules, codes, and regulations relating to the use of this safeguarding system in any particular application are satisfied.**

Specifications

Operating Distance	1-50 mm (0.04" - 2") max.
Switching Distance	See Figure 3
Mounting	Holes for M4 (#10) screw (not included)
Construction	Polycarbonate plastic housing and window; acrylic lens
Temperature range	0° to +70°C (+32° to 158°F)
Max. relative humidity	95% (non-condensing)
Environmental Rating	IEC IP65, NEMA 4, 13

SFI-S1L

SFI-S1R

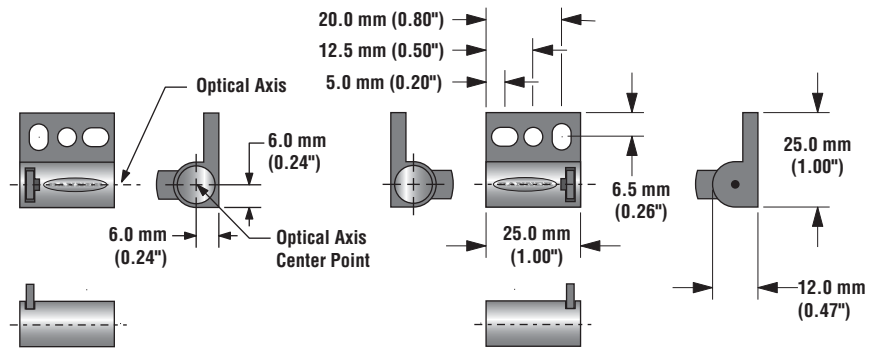

Models SFI-S1R and SFI-S1L

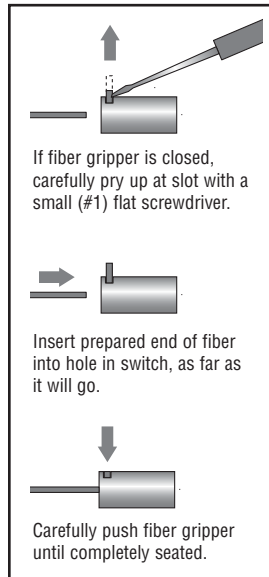

Figure 1. Fiber connections

Mounting and Fiber Connection

The path of travel, or movement, of the Fiber Optic Safety Interlock Switch **must always be perpendicular** (at a right angle) to the optical axis to ensure proper switching. Perpendicular displacement along the optical centerline greater than the switching distance will result in a beam break and a stop condition.

Any opening in a guard must comply with the minimum safe opening requirements to prevent exposure to a hazard. See OSHA O-10 Table listed in 29CFR1910.217 or the relevant standard for further information.

The use of tamper-resistant fasteners, such as one-way screws, is recommended. Insert the fasteners, but before tightening, verify alignment between the two switch housings using a straightedge or the alignment guide (SFA-IAG) shipped with the PICO-GUARD controller. Do not over-tighten or mount the fiber switch on an uneven surface such that the switch is deformed or bows, affecting the optical performance.

With the guard closed, the maximum allowed distance from lens face to lens face is 50 mm (2"). Ensure that there is a minimum 1 mm (0.04") separation between switches and do not use the switches as an end-of-travel or mechanical stop.

Do not exceed the minimum bend radius for the fiber optic cable to be used. The excess gain is dependent on switch pair alignment, fiber length, fiber bend radius, and other loss factors, which may result in a weak signal or beam break condition (e.g., increased transitional area, see Figure 2). See Bannerengineering.com for an on-line gain estimator or the Application and Design Guide for more information.

Switching Specifications

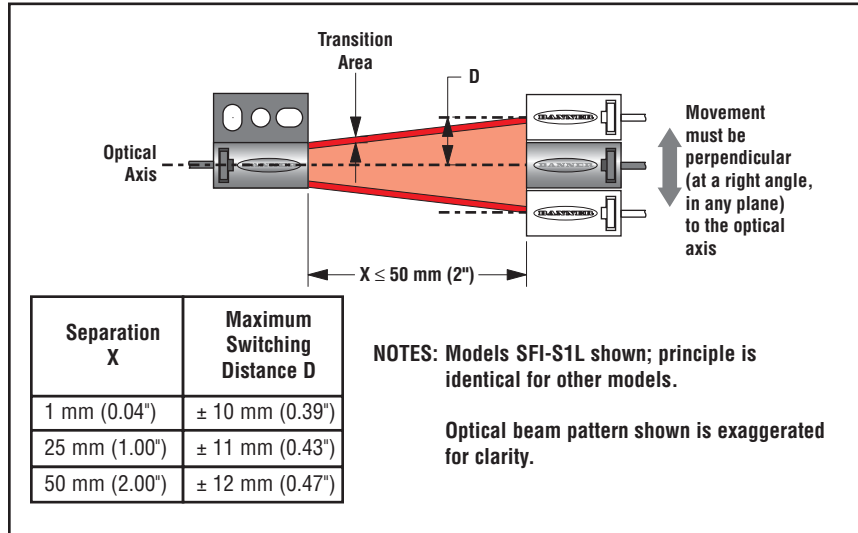

Figure 2. Switch alignment

The switching distance (D) is a “±” value; it is dependent on the distance between the optical switches (X) and their alignment along the optical axis. Perpendicular displacement greater than “D” will result in a stop condition. (See Application and Design Guide for complete information.)

The excess gain may fall below the threshold level before the switching distance dependent on alignment, fiber length, and other loss factors, which will result in a weak signal or beam break condition before distance D. This region is referred to as the **Transition Area**.



WARRANTY: Banner Engineering Corp. warrants its products to be free from defects for one year. Banner Engineering Corp. will repair or replace, free of charge, any product of its manufacture found to be defective at the time it is returned to the factory during the warranty period. This warranty does not cover damage or liability for the improper application of Banner products. This warranty is in lieu of any other warranty either expressed or implied.